

# Torque Sensor Series 5000



## Properties

- Non-contact measurement system, high robustness
- special for high torque applications
- „Plug & Play“ solution, no additional electronics required
- Maintenance operation

## Performance

- Measurement range from 10 kNm to 25 kNm
- Accuracy class 0,5 %
- Temperature range -40 °C ... +80 °C
- Tuning speed up to 5000 rpm
- Output signals 0-10 V / 4-20 mA / USB
- Optional angle sensors / speed sensor

### 1. Short description

The series 5000 is special build for high torque measurements. It's possible to measure the torque, that's incoming from the shaft, both static as well as by rotation bidirectional and independence from speed. The sensor is delivered as one complete unit with integrated electronics and cable.

The series 5000 is build in high robustness and for special performance applications. Through that, it's suitable perfect placed in test benches and for highest requirements in torque sensor systems. This series can be provide with a lot of options, like angle sensor, protection class IP65 and different output signals.

### 2. Model series 5000

Model Serie 5000		Nominal-Torque	Max. Overload	Rotational Speed
Shaft [mm]	Unit	bi-directional (+/-)	bi-directional (+/-)	[rpm]
1	[Nm]	10000 - 15000	20000	8000
2	[Nm]	16000 - 25000	30000	5000
3	[Nm]	>25000	on request	on request

## 3. Technical Characteristics

No.	type		series 5000
	Accuracy class <sup>1</sup>		0,5
		Unit	value
1	Linearity deviation incl. hysteresis	%ME*	< ±0,5
2	Rotational Signal Uniformity	%ME*	< ±0,5
3	Repeatability	%ME*	< ±0,1
	Output signal in general	Unit	value
4	Frequency range, -3dB point, Bessel characteristics	Hz	2500
5	Analog signal	V	0 ... 10
6	Signal bei torque = zero	V	≈ 5
7	Signal at positive nominal torque	V	> 5
8	Signal at negative nominal torque	V	< 5
9	Calibration parameter (normed)	mV/Nm	4000 mV / measurement range
10	Output resistance	Ω	50
11	Angle / speed	ppr / cpr	optional angle / speed sensors
	Temperature influence	Unit	value
12	Zero point drift over temperature	%/10K	< 0,5
13	Signal drift over temperature within operational temperature range <sup>2</sup>	%/10K	< 0,5
	Power supply	Unit	value
14	Supply voltage	VDC	9 ... 28
15	Max. consumption	mA	40
16	Start-up peak	mA	< 100
17	Max. absolute supply voltage	VDC	30
	General information	Unit	value
18	Degree of protection acc. to EN 60529	IP	65 in connected state
19	Reference temperature	°C	+15 ... +35
20	Operational temperature range	°C	-40 ... +105
21	Storage temperature range	°C	-40 ... +105
22	cable	m	Incl. 5 m cable with plug

\* %ME: related to a full scale measurement range

- 1) The accuracy class implies that taken separately both the linearity deviation as well as the rotational signal uniformity are either lower than or equal to the value of the accuracy class. The accuracy class is not to be identified with the classification following DIN 51309 or EA-10/14 .
- 2) The factor of transmission declines linearly up to a maximum of 0,5% / 10K with rising temperature due to the reduction of the elasticity.

# Torque Sensor Series 5000

## 4. Dimensions

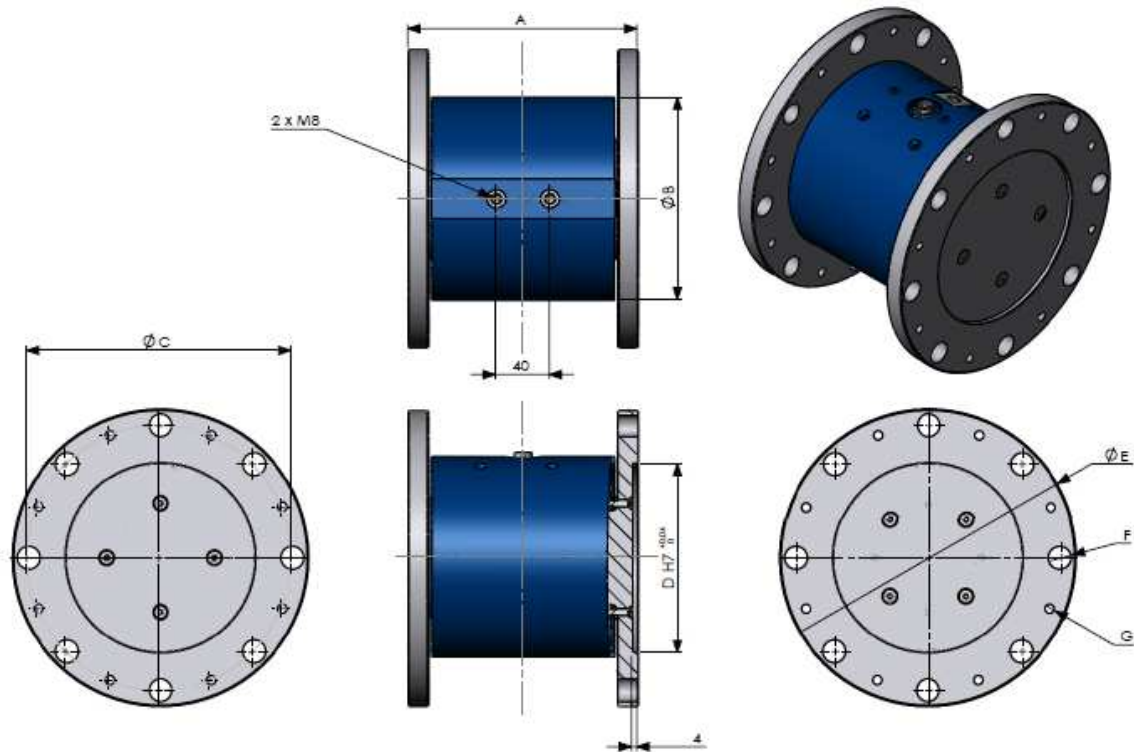

Sensor	size 1	size 2
dimension A in mm	170	200
dimension B in mm	150	190
dimension C in mm	196	288
dimension D in mm	140	174
dimension E in mm	220	326
dimension F in mm	17	19
dimension G	-	-
screws	8x M16, 10.9	8 x M18, 10.9
Tightening torque	125Nm	210Nm

## 5. Angle Sensor

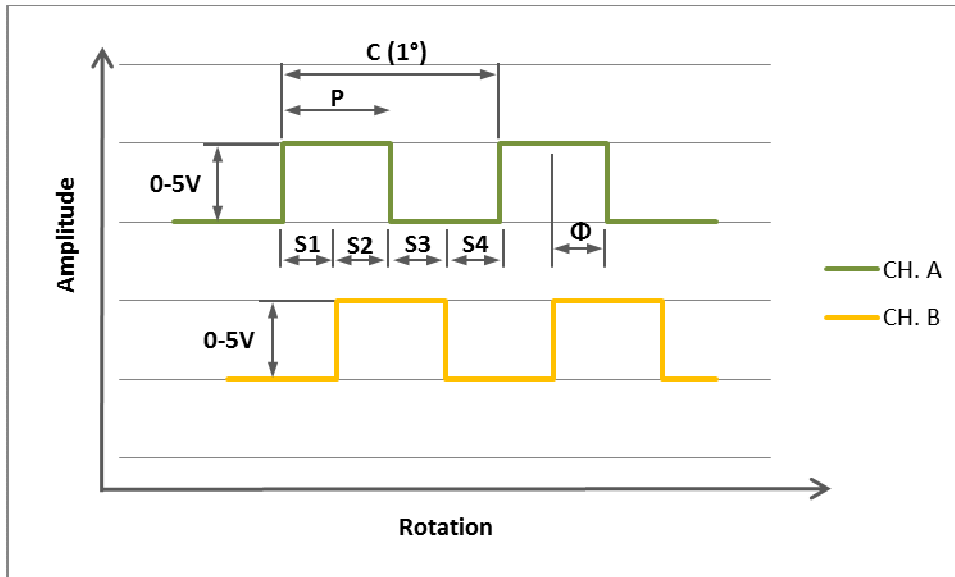

Parameter	Symbol	Min.	Typ.	Max.	Units
Pulse width error	$\Delta P$		15	55	$^{\circ}e$
Pulse width error (Ch.A, Ch. B)	$\Delta P$		15	55	$^{\circ}e$
Phase error	$\Delta \phi$		12	60	$^{\circ}e$
Current consumption	ICC		2,2	5,0	mA
High level output voltage	VOH	2,4	5		V
Low level output voltage	VOL			0,4	V
Rise time slopes	Tr		500		ns
Fall time slopes	tf		100		ns
Parameter	Description				
C	One cycle (Pulse) of 360 CPR (degrees)				
P	The duration of high state of the output within one cycle. Nominally $180^{\circ} e$ or half a cycle.				
S	The number of electrical degrees between a transition in Channel A and the neighboring transition in Channel B. There are 4 states per cycle, each nominally $90^{\circ} e$ .				
$\Phi$	The number of electrical degrees between the center of high state of Channel A and the center of high state of Channel B. Nominally $90^{\circ} e$ .				

## 6. Connection plan

Pin assignment at sensor  
Presentation: Top view

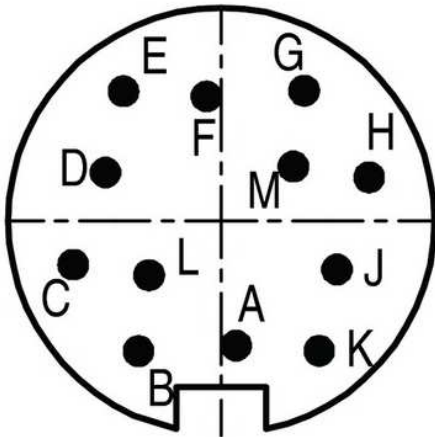

Binder series M16 connector IP67			
Model	Item-No.: 09-0131-90-12		
Color code according to DIN 47100			
Pin	color	description	value
A	white	USB D- / CAN-H	
B	brown	USB D+ / CAN-L	
C	green	Angle Channel A	0 ... 5 V
D	yellow	Angle Channel B	0 ... 5 V
E	grey	Analog GND	
F	pink	Analog voltage / Analog current	0 ... 10 V / 4 ... 20 mA
G	blue	Ground GND	
H	red	Supply voltage $V_{CC}$	9 ... 28 V
I	black	-	
K	violet	-	
L	Grey-pink	-	
M	red-blue	-	

Ex. for connection:

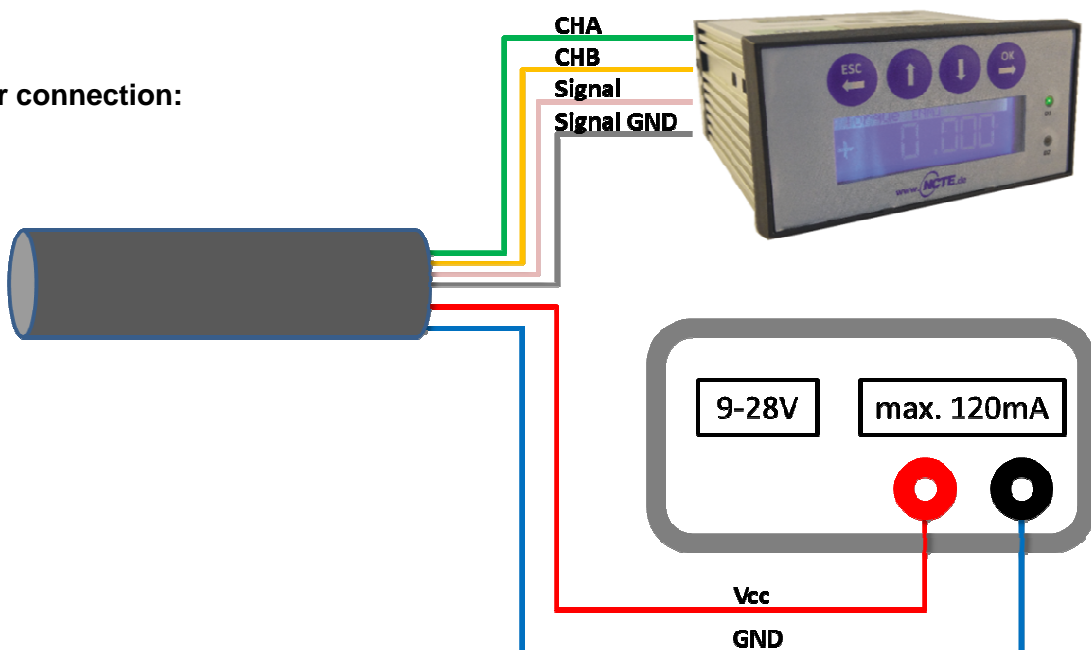

## 7. Instruction manual

### Field of application

The torque sensor is intended mainly for the use in test benches and for highest torque measurements.

### Scope of delivery

The torque sensor set consists of the sensor itself (signal pick-up and signal processing integrated into sensor housing), one connection cable with a soldered plug.

### Installation and Removal

Make sure to install the sensor shafts exactly with the proper aligned connecting shafts. The sensor is not designed as a pillow block. No external axial or radial force should be applied to the housing of the sensor. In case that the bending or radial forces could not be avoided the ball bearing of the sensor must be double-checked. The sensor is not designed for trailing loads, please load only compressive forces on the shaft ends. A maximum cable length of 5 m must not be exceeded. Using a cable or connector other than supplied by NCTE, or a similar cable that is of a different length may affect the overall performance of the sensor.

**Do not remove the shaft with torque applied to the sensor.**

### Adjustment

If required the zero point output signal (5 V / 12 mA) can be adjusted. By factory default the sensor is set to 5 V or 12 mA at zero torque.

### Interface description

#### Mechanical connections:

For torque transmission use the right mounting parts from a qualified supplier, also do not hesitate to ask NCTE.

#### Electrical connector:

On the sensor housing there is a 12-pin socket for the power supply and the signal output. (Pin-assignment please see chapter 6. connection plan).

### Operation (in regular case or in optimization)

Optimal measurement parameters may be achieved, when the sensor is applied in accordance to the specification. Use the sensor only for short periods of time at the maximum rotational speed. By compliance with the specification the sensor works generally trouble-free and maintenance-free.

### Irregular Operation, Measures against disturbance

The presence of external electromagnetic or magnetic fields can lead to irregular measurement results. The mechanical overload on the sensor (eg. exceeding of maximum allowed torque or severe vibrations) may cause damage to the sensor and in consequence the incorrect signal output. In such cases the sensor must be reset. If this does not help, do not open the sensor, but contact NCTE directly for assistance.

# Torque Sensor Series 5000



## Commissioning

After sensor installation pay attention to the followings:

- Switch on the power supply unit and check the supply voltage. Peak voltage to the sensor must be avoided! Be sure to verify the power supply voltage before connecting the sensor!
- Connect the sensor to the power supply unit by using the delivered cable.
- Connect the sensor output to a high-resistance device such as an A/D converter, oscilloscope, PC measurement board. The sensor should be in mechanical unloaded state while connecting it.

## Service / Maintenance

Service-contact:

phone: ++49 89 66 56 19 0

facsimile: ++49 89 66 56 19 29

The sensor is free of maintenance, NCTE advises a yearly recalibration. The ball bearing is designed for a lifetime of 5000 h.

## Disposal

For purposes of disposal please send the sensor back to NCTE.

## Handling and transport

While handling, storing and transportation keep sensor away from magnetic and electromagnetic fields which may exceed the allowed maximum range of EMC listed in chapter 3. technical Characteristics.

## Precautions

- Do not open the sensor under any circumstances.
- Do not remove or loosen the locking rings on the shaft ends.
- The mounting nut of the socket as well as the fixing screws should not be loosened or tightened.
- Use only a separate power supply for the sensor.
- Use the sensor only according to the specification (chapter 3. Technical Characteristics).
- Keep the sensor away from magnetic and electromagnetic fields which may exceed the allowed maximum range of EMC (chapter 3. Technical Characteristics),
- The sensor is not designed as a pillow block. The existing fixing possibilities serve exclusively for preventing the sensor from rotation.

# Torque Sensor Series 5000

## 8. Order options

series 5000 Accuracy 0,5%							Price
<b>Measurement range</b>							
	10kNm						
	15kNm						
	20 kNm						
	25 kNm						
	XXkNm	customized calibration					
<b>Option 3: Angle sensor / speed sensor</b>							
	0	without angle sensor					
	1	Speedsensor 1CPR					
	2	Speedsensor 60CPR					
	3	angle sensor 1024 PPR					
<b>Option 4: Output signal</b>							
	A	Analog voltage 0-10 V					
	S	current output 4-20 mA					
	C	CAN-Bus					
<b>Option 5: Protection class</b>							
	0	IP50					
	1	IP65					
5000	x		x	x	x		

### Read Out Unit for all NCTE Sensors



Ord.-No. 40010-ATS001

- Compact readout box with display
- 1 torque sensor input, 0-5V and 0-10V
- 1 angle encoder input, A/B
- 2x digital output
- USB interface, Windows software included
- SD card slot

## 9. Contact

[www.guemisa.com](http://www.guemisa.com) **SENSORES E INSTRUMENTACION GUEMISA S.L.**

 C\ La Fundación 4 Bis - Pl 1ª Oficina-2  
28522 Rivas Vaciamadrid (Madrid)  
Telf. 91 764 21 00 email: [ventas@guemisa.com](mailto:ventas@guemisa.com)

NIF: B-87969416