

## Technical data



- Nominal torque: 2,5 Nm to 100 Nm, bidirectional
- Rotational speed:  $\leq 10.000$  rpm
- Accuracy:  $\leq \pm 0,5$  %
- Temperature range:  $-30$  °C to  $+85$  °C
- Protection class: IP50, IP65
- Output signals: 0-10 V/4-20 mA/CAN-Bus/USB
- Output frequency: 1.000 Hz

## Your advantages

- Made in Germany (nearby Munich, Bavaria)
- Delivery ex warehouse (< two weeks)
- Best price-performance ratio
- Integrated electronic (Plug & Play)
- Contactless measurement system
- Including 5 m cable and calibration certificate

### Short description

The 2300 series is the most cost-effective entry into professional torque measurement technology.

This series is mainly used in automotive test facilities, professional testing construction, climatic exposure test cabinets (exceeding dew point), process monitoring and medical engineering.

Transmitted torque can be measured statically and dynamically in real time. Shaft is available as Round shaft and Square shaft. Each sensor can be configured individually with a lot of extras, such as angle sensor and protection class IP65.

Series 2300 offers a wide range of output signals such as 0-10 V, 4-20 mA, CAN-Bus or USB. USB is offered including a special NCTE software enables to show data in real time.

The sensor is provided as a complete unit with integrated evaluation electronic, including 5 m cable, keystones (Round shaft) and calibration certificate.

 **www.guemisa.com** **SENSORES E INSTRUMENTACION GUEMISA S.L.**  
C\ La Fundación 4 Bis - Pl 1ª Oficina-2  
28522 Rivas Vaciamadrid (Madrid)  
Telf. 91 764 21 00 email: [ventas@guemisa.com](mailto:ventas@guemisa.com)  
NIF: B-87969416

### Model series 2300

Model series 2300 round shaft	Unit	Nominal torque bidirectional (+/-)	Max. load bidirectional (+/-)	Rotational speed [rpm]
Ø 9 mm	[Nm]	2,5	5	10.000
		5	10	
		10	20	
		20	40	
Ø 15 mm		50	100	
		100	200	

Model series 2300 square shaft	Unit	Nominal torque bidirectional (+/-)	Max. load bidirectional (+/-)	Rotational speed [rpm]
¼ inch	[Nm]	2,5	5	5.000 <sup>1</sup>
		5	10	
		10	15	
		20	30	
⅜ inch		50	100	
		100	200	

### Load characteristics

Model series 2300 measuring range	Unit	Axial force [N] <sup>2</sup>	Lateral limit force [N]	Bending limit moment [Nm]
2,5 and 5	[Nm]	1.000	20	2,5
10 and 20		1.000	30	3,7
50 and 100		1.000	100	12,5

Each type of irregular stress can only be permitted with its given limit value (bending moment, lateral force or axial force, exceeding the nominal torque) if none of the others can occur. Otherwise the permitted limits must be reduced. If for instance 30 % of the limited bending moment and also 30 % of the limited lateral force are present, only 40 % of the limited axial force are permitted, provided that the nominal torque is not exceeded.

<sup>1</sup> Higher speed possible in clearance-free adaption.

<sup>2</sup> Direct acting axial force on the shaft. If the force affects the snap ring, just 50 % of the force is permitted.

## Technical characteristics

No.	Model	Unit	Series 2300	
	Accuracy class <sup>3</sup>		0,5	
		Unit	Value	
1	Linearity deviation incl. hysteresis	%ME <sup>4</sup>	< ±0,5	
2	Rotational Signal Uniformity (RSU)		< ±0,5	
3	Repeatability		< ±0,05	
Output signal in general		Unit	Value	
4	Frequency range, -3dB point, Bessel characteristics	Hz	1.000	
5	Analog signal	V   mA	0 ... 10	4 ... 20
6	Signal at torque = Zero <sup>5</sup>	V   mA	5	12
7	Signal at positive nominal torque <sup>5</sup>	V   mA	9	20
8	Signal at negative nominal torque <sup>5</sup>	V   mA	1	4
9	Calibration parameter (normed) <sup>5</sup>	V/Nm mA/Nm	4 V/Measurement range	8 mA/Measurement range
10	Error output	V   mA	10	22
11	Output resistance	Ω	< 1	
Effect of temperature		Unit	Value	
12	Zero point drift over temperature	%/10 K	< 0,15	
13	Signal drift over temperature within nominal temperature range	%/10 K	< 0,1	
Power supply		Unit	Value	
14	Supply voltage	VDC	5 ... 28	
15	Current consumption (max.)	mA	37 ... 45	
16	Start-up peak	mA	< 100	
17	Absolute max. supply voltage	VDC	30	
General information		Unit	Value	
18	Protection class according to EN 60529 <sup>6</sup>	IP	50/65	
19	Reference temperature	°C	+15 ... +35	
20	Operational temperature range	°C	-30 ... +85	
21	Storage temperature range	°C	-30 ... +85	
22	Bearing operating hours	h	approx. 20.000	

<sup>3</sup> The accuracy class implies that taken separately both the linearity deviation as well as the rotational signal uniformity are either lower than or equal to the value of the accuracy class.

<sup>4</sup> %ME: related to a full scale measurement range.

<sup>5</sup> Please check the exact data at the sensors calibration certificate.

<sup>6</sup> Wiring connected.

Nominal rated torque M (bi-directional)		Nm	2,5	5	10	20	50	100
23	Weight	Rd	g		380	390	550	
		Sq	g		370	380	510	
24	Moment of inertia	Rd	g mm <sup>2</sup>		546	698	4.535	
		Sq	g mm <sup>2</sup>		318	470	2.951	

**Dimensions**

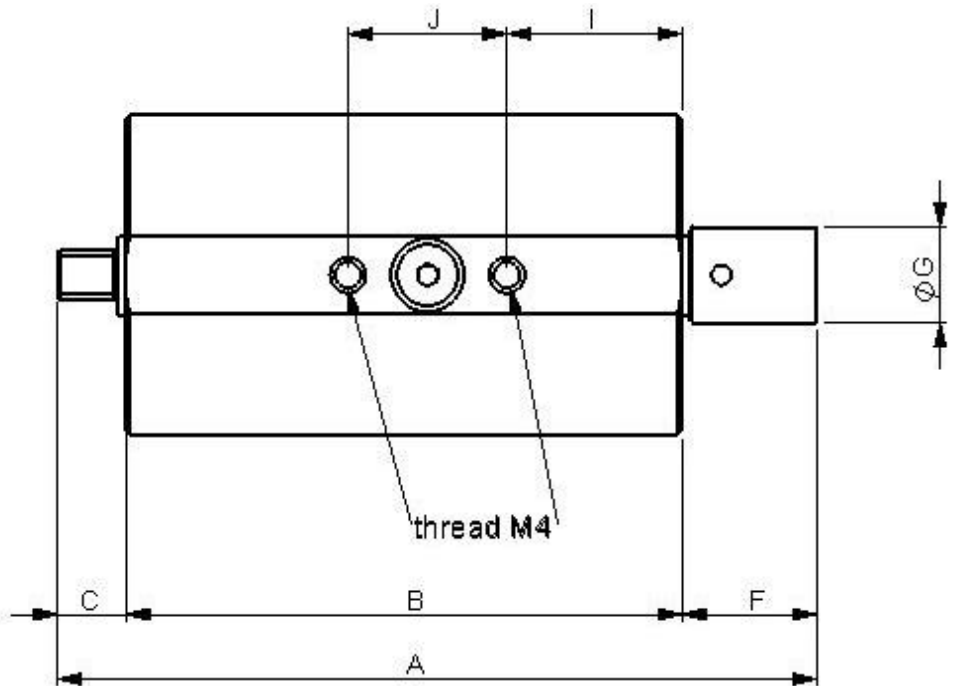
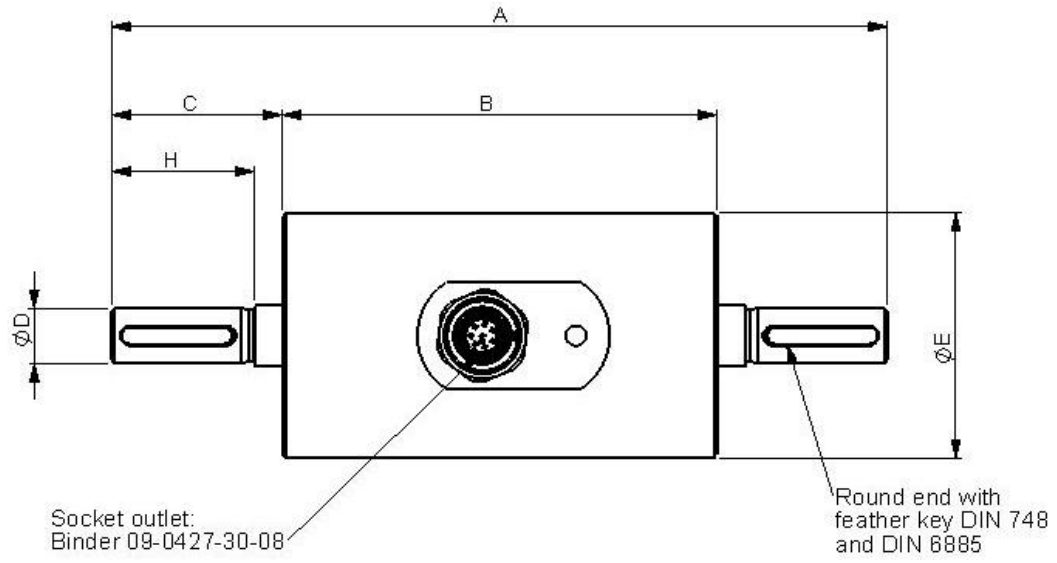

Dimensions	Round shaft nominal torque [Nm]		Square shaft nominal torque [Nm]	
	Ø 9 mm	Ø 15 mm	1/4 inch	3/8 inch
Nominal torque [Nm]	2,5 - 5 - 10 - 20	50 - 100	2,5 - 5 - 10 - 20	50 - 100
A	125	139	95,5	107
B	70	70	70	70
C	27,5	35	8,5	12
D	9g6	15g6	-	-
E	40	50	40	50
F	-	-	16	24
G	-	-	12	18
H	23	-	-	-
I	22	22	22	22
J	20	20	20	20

Dimensions keyway [mm]				Keystones		
Round shaft	Width	Depth	Length	Height	Length	Amount
Ø 9 mm	3	1,8	18,5	3	18	1
Ø 15 mm	5	3	25,5	5	25	1

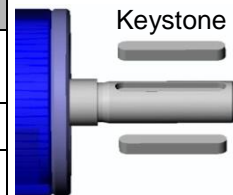

**Connection plan**

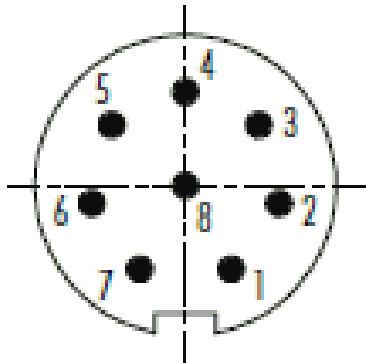

Connector  
Power supply and outputs

Binder series s712-M9 connector IP67 colour coding according to DIN 47100			
Pin	Color	Description	Value
1	White	USB/CAN-Bus	D-/H
2	Brown	USB/CAN-Bus	D+/L
3	Green	Angle Channel A	0 V ... 5 V
4	Yellow	Angle Channel B	0 V ... 5 V
5	Grey	Analog GND	-
6	Pink	Signal Output analog Voltage/Current	0 V ... 10 V 4 mA ... 20 mA
7	Blue	Ground GND	-
8	Red	Ground V <sub>CC</sub>	5 V ... 28 V

Connection example:

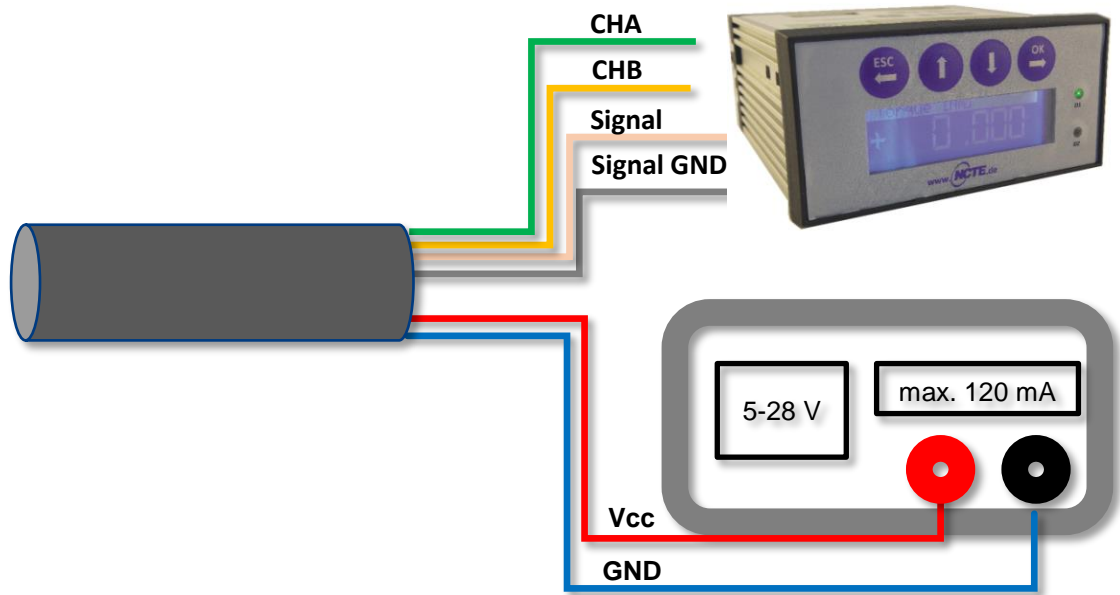

## Angle sensor

Optical angle sensor with 360 CPR.

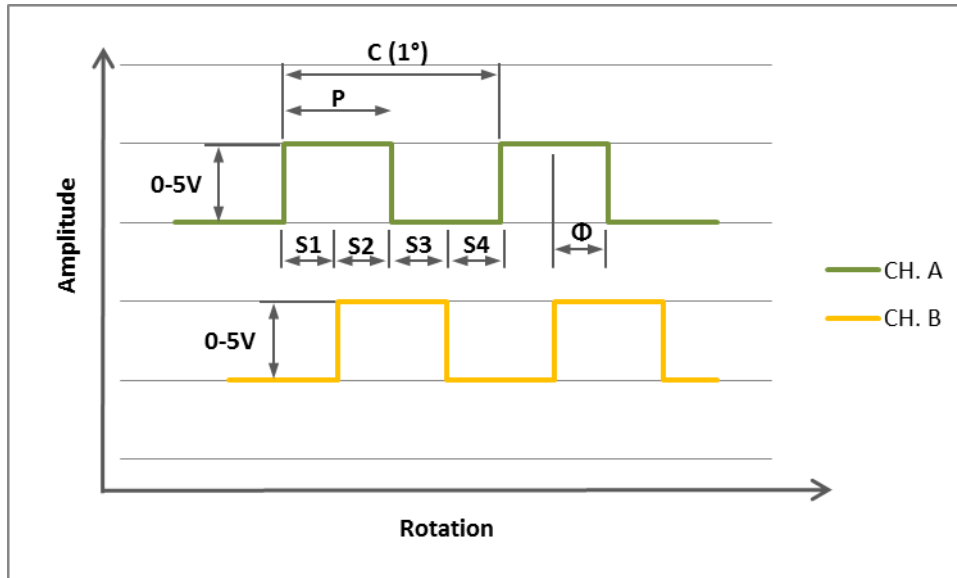

Parameter	Min.	Typ.	Max.	Units
High Level Output Voltage	2,4	5	-	V
Low Level Output Voltage	0	-	0,4	V
Parameter	Description			
C	One cycle of 360 CPR (degrees)			
P	The duration of high state of the output within one cycle.			
S	The number of electrical degrees between a transition in Channel A and the neighboring transition in Channel B.			
Φ	The number of electrical degrees between the center of high state of Channel A and the Center of high state of Channel B.			

**Order options**

Series 2300 accuracy 0,5 %		Price
<b>Measurement range</b>		
2,5	Nm including 5 m cable and calibration certificate	
5	Nm including 5 m cable and calibration certificate	
10	Nm including 5 m cable and calibration certificate	
20	Nm including 5 m cable and calibration certificate	
50	Nm including 5 m cable and calibration certificate	
100	Nm including 5 m cable and calibration certificate	
<b>Angle sensor</b>		
0	Without angle sensor	
1	Angle sensor 360CPR	
<b>Analog output</b>		
A	Voltage output 0-10 V	
S	Current output 4-20 mA	
<b>Digital output (optional)</b>		
U	USB incl. NCTE Software and 2,8 m cable	
C	CAN-Bus	
<b>Shaft ends</b>		
0	Round shaft with keystone	
1	Square shaft	
<b>Protection class according to EN 60529</b>		
0	IP50	
1	IP65	
2300		



## Instruction manual

### Scope of delivery

The torque sensor set consists of the sensor itself (signal pick-up and signal processing integrated into sensor housing), one **connecting cable** 5 m with a **soldered plug** (binder plug no. 99-0426-10-08), **key stones** (round shaft) and the calibration certificate.

USB-cable will be delivered in 2,80 m length.

Datasheets and instruction manuals are available at [www.ncte.com](http://www.ncte.com).

### Installation and removal

Make sure to install the sensor shafts exactly with the proper aligned connecting shafts. The key stone adapter/square endings of the connecting shafts are to be attached forceless to the corresponding ones of the sensor. No external axial force should be on the housing of the sensor from distortion. A maximum cable length of 5 m must not to be exceeded. Using a cable or connector other than supplied by **NCTE**, or a similar cable that is of a different length may affect the overall performance of the sensor.

Do not remove the shaft with torque applied to the sensor.

### Interface description

Mechanical connection:

The key stone adapters on both ends of the measurement shaft are intended for torque transmission.

Electrical connector:

On the sensor housing there is a 8-pin socket for the power supply and the signal output (see chapter connection plan).

### Operation (in regular case or in optimal case)

Optimal measurement parameters can be achieved if the sensor is applied in accordance to the specification. By compliance with the specification the sensor works generally trouble-free and maintenance-free.

### Irregular operation, measures against disturbance

The mechanical overload on the sensor (e. g. exceeding of maximum allowed torque or severe vibrations) may cause damage to the sensor and in consequence the incorrect signal output. In such cases please do not open the sensor. Contact **NCTE** directly for assistance.

### Commissioning

After sensor installation pay attention to the following:

- Switch on the power supply unit and check the supply voltage. Peak voltage must be avoided! Be sure to verify the power supply voltage before connecting the sensor!
- Connect the sensor to the power supply unit by using the delivered cable.
- Connect the sensor output to a high-resistance device such as an A/D converter, oscilloscope, PC measurement board. The sensor should be in mechanical unloaded state while connecting it.

### Shaft coating

The shafts are protected on both sides with a film of anticorrosion wax. We recommend to leave the protection permanent. As far as technologically needed, the coating can be removed with spirit / ethanol

### Handling and transportation

By handling, storage and transportation keep the sensor away from magnetic or electromagnetic fields which may exceed the maximal intensity defined from EMC (chapter technical characteristics) for instance degaussing machines.

### Precautions

- Do not open the sensor housing under any circumstances.
- Do not remove or loosen the locking rings on the shaft ends.
- Do not loosen or tighten the flange-mounting nut of the socket-connector (chapter dimensions).
- Use only a separate power supply for the sensor.
- Use the sensor only according to the specification (chapter technical characteristics).

### Service and maintenance

#### Recommended NCTE maintenance plan

Recalibration	12 month
Control of wiring, plug and shaft	12 month



#### **GUEMISA**

Sta. Virgilia, 29 - 28033 Madrid - Tfno.: 91 764 21 00  
Desde 1986 suministrando sensores e instrumentación  
<http://www.guemisa.com> - [ventas@guemisa.com](mailto:ventas@guemisa.com)

