

gm **SENSORES E INSTRUMENTACION GUEMISA S.L.**
 NIF: B-87969416

C\ La Fundición 4 Bis - Pl 1ª Oficina-2
 28522 Rivas Vaciamadrid (Madrid)
 Telf. 91 764 21 00
 email: ventas@guemisa.com

www.guemisa.com

Position Transducer with return spring potentiometric up to 200 mm, IP54

Series TEX

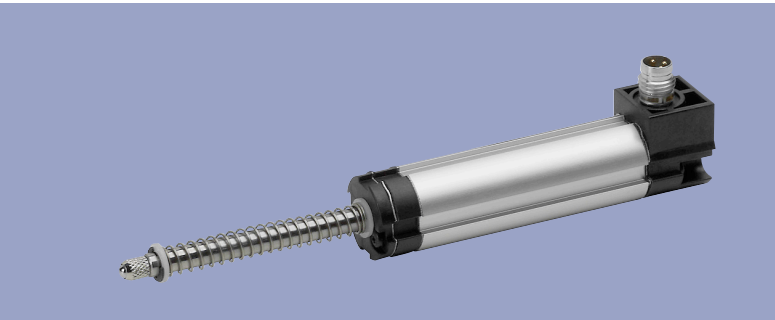

Special features

- Position transducer with return spring
- outstanding linearity up to $\pm 0.05\%$
- resolution better than 0.01 mm
- very long life - up to 50 million movements (application dependent)
- compact dimensions
- protection class IP54
- threaded shaft allows customer-defined mechanical interfaces
- compatible to standard probe tips
- cable or connector versions available

This cost effective transducer is characterized by its various mounting options and compact dimensions. Flexible mounting clamps or central mounting allow easy mounting under various conditions.

For transducers without return spring and pivot head mounting, please see separate data sheets.

Typical applications are linear position measurements for process control and display, and the test lab environment.

The return spring design allows a direct measurement without a fixed connection to the moving part.

The electrical connection is provided by an M8 connector or a cable, which exits either radially or axially from the housing.

Description	
Housing	aluminium, anodized
Mounting	see drawing
Actuating rod	stainless steel (1.4305), rotatable. Probe tip stainless steel with external thread M2.5 and pressed-in hardened metal ball
Bearings	sleeve bearing
Resistance element	conductive plastic
Wiper assembly	precious metal multi-finger wiper
Electrical connections	3-pin round connector M8x1 3-wire PUR-cable, 3x0.14 mm ² , shielded, 2 m or 5 m length

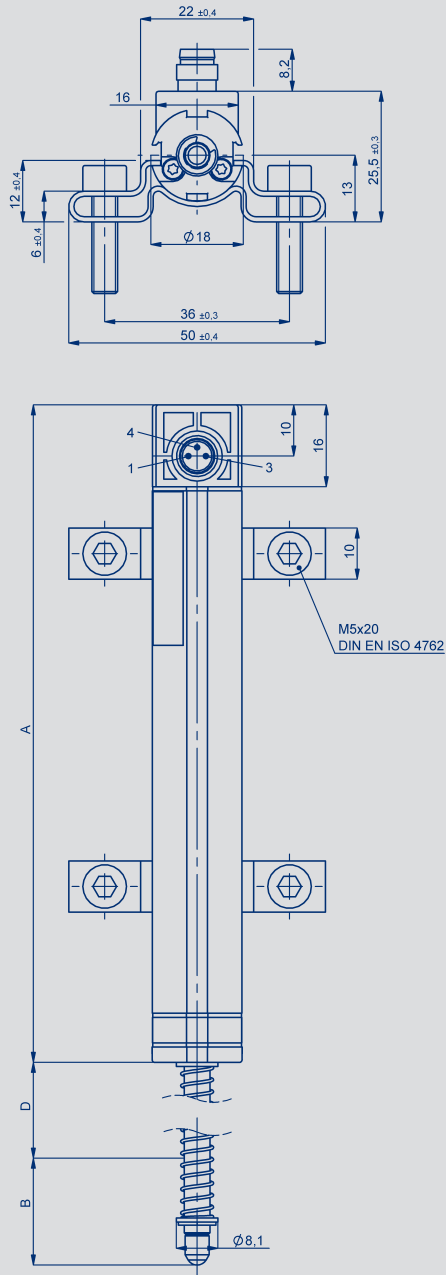

Central mounting style

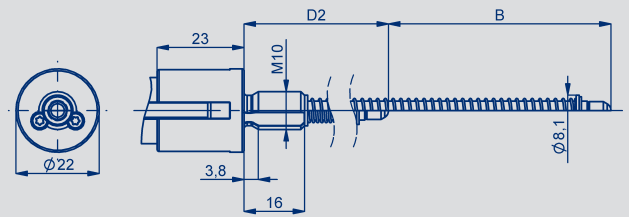

Tightening torque max. 5 Nm

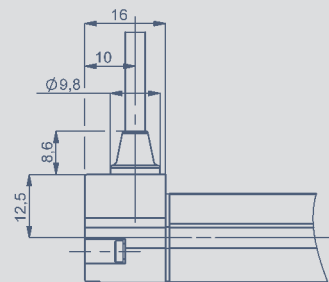
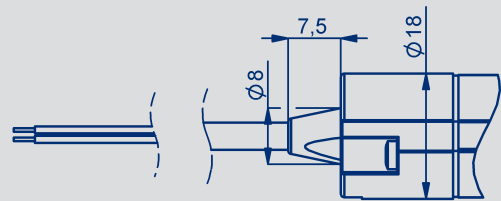

Type designations	TEX 0010	TEX 0025	TEX 0050	TEX 0075	TEX 0100	TEX 0125	TEX 0150	TEX 0175	TEX 0200	
Electrical Data										
Defined electrical range	10	25	50	75	100	125	150	175	200	mm
Electrical range	12	27	52	77	102	130	155	180	205	mm
Nominal resistance	1	1	2	3	4	5	6	7	8	kΩ
Resistance tolerance	20									±%
Independent linearity	0.25	0.2	0.1	0.1	0.1	0.05	0.05	0.05	0.05	±%
Repeatability	0.01 (without side loads)									mm
Recommended operating wiper current	≤ 1									μA
Maximum wiper current (in case of malfunction)	10									mA
Maximum permissible applied voltage	42									V
Effective temperature coefficient of the output-to-applied voltage ratio	typical 5									ppm/K
Insulation resistance (500 DC)	≥ 10									MΩ
Dielectric strength (500 VAC, 50 Hz)	≤ 100									μA
Mechanical Data										
Body length (dimension A)	63	78	103	128	153	194	219	244	269	±2 mm
Mechanical stroke (dimension B)	14	29	54	79	104	132	157	182	207	±2 mm
Dimension D	25	25	50	75	95	98	105	113	121	±2 mm
Dimension D2	41	41	50	75	95	98	105			±2 mm
Weight approx. cable version TEX-_-_-42_-002-202	80	85	95	105	115	155	165	175	185	g
connector version TEX-_-_-42_-002-101	50	55	65	75	85	125	135	145	155	g
additional weight central mounting	10									g
Operating force horizontal	5.6 (at RT 20° C)									±0.8 N
Operating frequency max. in center position	49	43	35	28	24	21	20	20	20	±2 mm
Environmental Data										
Temperature range	-40 ... +85									°C
Operating humidity range	0 ... 95 (no condensation)									% R.H.
Vibration	5...2000 Amax = 0.75 amax = 20 g									Hz mm g
Shock	50 6									g ms
Life	> 50 x 10 ⁶ typ.									movements
Operating speed	5									m/s max.
Protection class	IP54 DIN EN 60529									

Ordering specifications

TEX - 0150 - 421 - 002 - 202									
Series			Electrical version 002: linearized (standard)			Electrical connection 101: 3-pin round connector M8x1, radial output 202: NT standard cable 2 m, radial output 205: NT standard cable 5 m, radial output 302: NT standard cable 2 m, axial output 305: NT standard cable 5 m, axial output			
Mechanical mounting 1: Fixing clamps 8: Central mounting M10 with collar - up to 0150 mm stroke			Mechanical version actuating rod_2 2: Transducer with return spring and probe tip			Protection class 4: one-side actuating rod			
Electrical defined range Standard lengths 0010 up to 200 mm									

Mounting instructions

A ball coupling is recommended for backlash-free and side load-free operation to compensate parallel or angular errors between transducer axis and the direction of movement.

Important

All values specified in this data sheet for linearity, lifetime and temperature coefficient are only valid for a sensor used as a voltage divider with virtually no load applied to the wiper ($\leq 1 \mu\text{A}$).

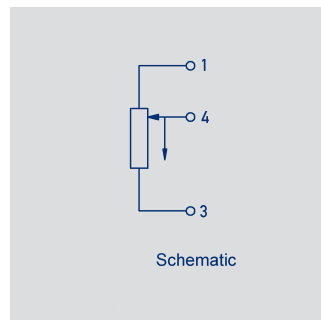
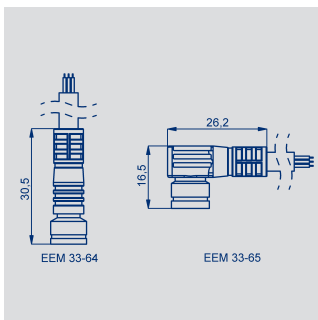

Output connector Code 101	Cable Code 202, 205 302, 305	Connector with cable EEM 33-64 / -66 / -68 / -65 / -67 / -69
PIN 1	BN brown	BN brown
PIN 4	WH white	BK black
PIN 3	GN green	BU blue

Optional accessories

Cable set - PUR cable with straight 3-pin mating connector - M8x1, 3x0.34 mm², IP67, unshielded

2 m length, EEM-33-64. P/N 005617

5 m length, EEM-33-66, P/N 005619

10 m length, EEM-33-68, P/N 005643.

Cable set - PUR cable with 90° angle 3-pin mating connector - M8x1, 3x0.34 mm², IP67, unshielded

2 m length, EEM-33-65. P/N 005618

5 m length, EEM-33-67, P/N 005620

10 m length, EEM-33-69, P/N 005644.

Other cable on request.

MAP - process control measurement/display device

MUP/MUK signal conditioners ± 24 V supply, 0-10 V or

4-20 / 0-20 mA current outputs.

Included in delivery

Clamp mounting: 2 clamps
incl. 4 cylinder head screws
M5x20.

