



- **Bearing unit with integrated torque sensor**
- **Measurement range from 0 to 500Nm bidirectional**
- **High tolerable dynamic loads**
- **High tolerable transverse forces and bending moments**
- **Maintenance-free operation**
- **Torque measurement up to 10,000rpm**
- **Integrated signal conditioning**
- **Analogue output signal**

1. Short description

The DML 500 is a fully-fledged spindle bearing unit with high running smoothness, load capacity and stiffness. A torque sensor is fully integrated into the spindle bearing unit. With this torque sensor, the effective torque can be measured bidirectionally in real time both at rest and in rotation. The sensor is delivered as a complete unit with corresponding connection plugs. The transmitting shaft, the contact-free signal pick-up and the analogue signal processing are integrated into the sensor structure. The torque sensor is particularly characterised by the insensitivity of the measurement signal to transverse and longitudinal forces, by the very low power consumption, and by a high long-term stability. Due to the completely non-contact magnetoelastic measurement principle, the sensor is also stable and reliable under harsh ambient conditions.

2. Technical characteristics of the sensor

Model		DML 500	
Accuracy class		0.1	
No.	Nominal torque M_{nom} (bidirectional)	Nm	500
Speed range		rpm	0 ... 10,000
Output signal		Unit	Value
1	Measurement frequency range	Hz	5000 (-3dB)
2	Analogue signal	V	0... 10
3	Signal with torque = zero	V	≈ 5.0
4	Signal with positive nominal torque (+500Nm)	V	≈ 9.5
5	Signal with negative nominal torque (-500Nm)	V	≈ 0.5
6	Nominal sensitivity	Nm / V	111.0
7	Sensitivity S	Nm / V	See label for calibration value
8	Relative standard deviation of repeatability	% ME	<± 0.1
9	Linearity deviation	% ME	<± 0.1
10	RSU (Rotational Signal Uniformity)	% ME	<± 0.2
11	Output resistance	Ω	270
Signal stability		Unit	Value
12	Long-term drift over 48 h	mV	<1
13	Zero drift over the temperature	% / 10K	± 0.1
14	Output signal over temperature in service temperature range ¹⁾	% / 10K	0.5
Energy supply		Unit	Value
15	Power supply	VDC	16...24
16	Maximum current consumption	mA	< 120
17	Start-up peak current consumption	mA	125... 150 (typically 135)
18	Rated power consumption	W	2.6
19	Minimum/maximum tolerable peak voltage	VDC	14... 30
General information		Unit	Value
20	Degree of protection acc. to EN 60529	-	IP 54
21	Weight	kg	26.5
22	Reference temperature	°C	+23
23	Service temperature range	°C	+10... +100
24	Storage temperature range	°C	-20...+100
25	Ambient temperature ²⁾	°C	0...+45

%ME: percent with regard to full-scale reading.

¹⁾ The sensitivity S decreases linearly with increasing temperature of up to 0.5% / 10K.

²⁾ Lower ambient temperatures can be released upon request, taking into account a starting cycle.

2. Technical characteristics of the sensor

No.	EMC	Unit	Value
Interference immunity (DIN EN61000-6)			
25	Electromagnetic field		
26	Housing	V/m	10
28	Magnetic field	A/m	30
29	Burst	kV	1
30	ESD	kV	2
Electromagnetic interference (EN55011; EM55022; EN55014)			
31	Interference voltage	-	Class A
32	Radio interference power	-	Class A
33	Disturbance field strengths	-	Class A
Shock resistance in accordance with DIN EN 60068-2-7			
34	Quantity	n	6000 (1000 / direction)
35	Directions	n	6 (3 positive; 3 negative)
35	Duration	ms	11
36	Acceleration (semi-sine)	g	65
Resistance to vibration in accordance with DIN EN 60086-2-6			
37	Frequency range	Hz	5 to 200
38	Duration	h	1.5 / direction
39	Direction	n	3
40	Amplitude of displacement	mm	11
41	Amplitude of acceleration	g	5
Maximum loads³⁾			
42	Maximum gaugeable torque	Nm	550
43	Limit torque in terms of M_{nom}	%	400
44	Breaking torque in terms of M_{nom}	%	590
Mechanical values			
45	Torsional rigidity C_T	kNm/rad	127,4
46	Twisting angle in terms of M_{nom}	Grad	0.22
47	Balancing grade in accordance with DIN ISO 1940	G	2.5
48	Moment of inertia (centre of mass)	kg mm ²	1599

³⁾ Due to the non-contact measuring principle, the torque sensor is largely insensitive to stresses of any kind. Only massive overloading of the sensor shaft leads to a permanent change in the sensor system. The limit torque and the breaking torque are valid for purely static loading and with no other applied loads. The permissible load spectrum always applies to the longitudinal and transverse forces (see section 5). The data on the accuracy of the output signal only applies to the rated torque, not to the maximum torque.

All information without guarantee and subject to technical changes

3. Geometric versions

The DML 500 can be produced as two versions. In the left version, the electronics box is fixed to the left hand side and on the right version, it is found accordingly on the right. In the diagram in the data sheet, the left version is shown. The designation of sides always follows the direction of propulsion – drive side seen. The type plate is always located on the left hand side.

4. Dimensions

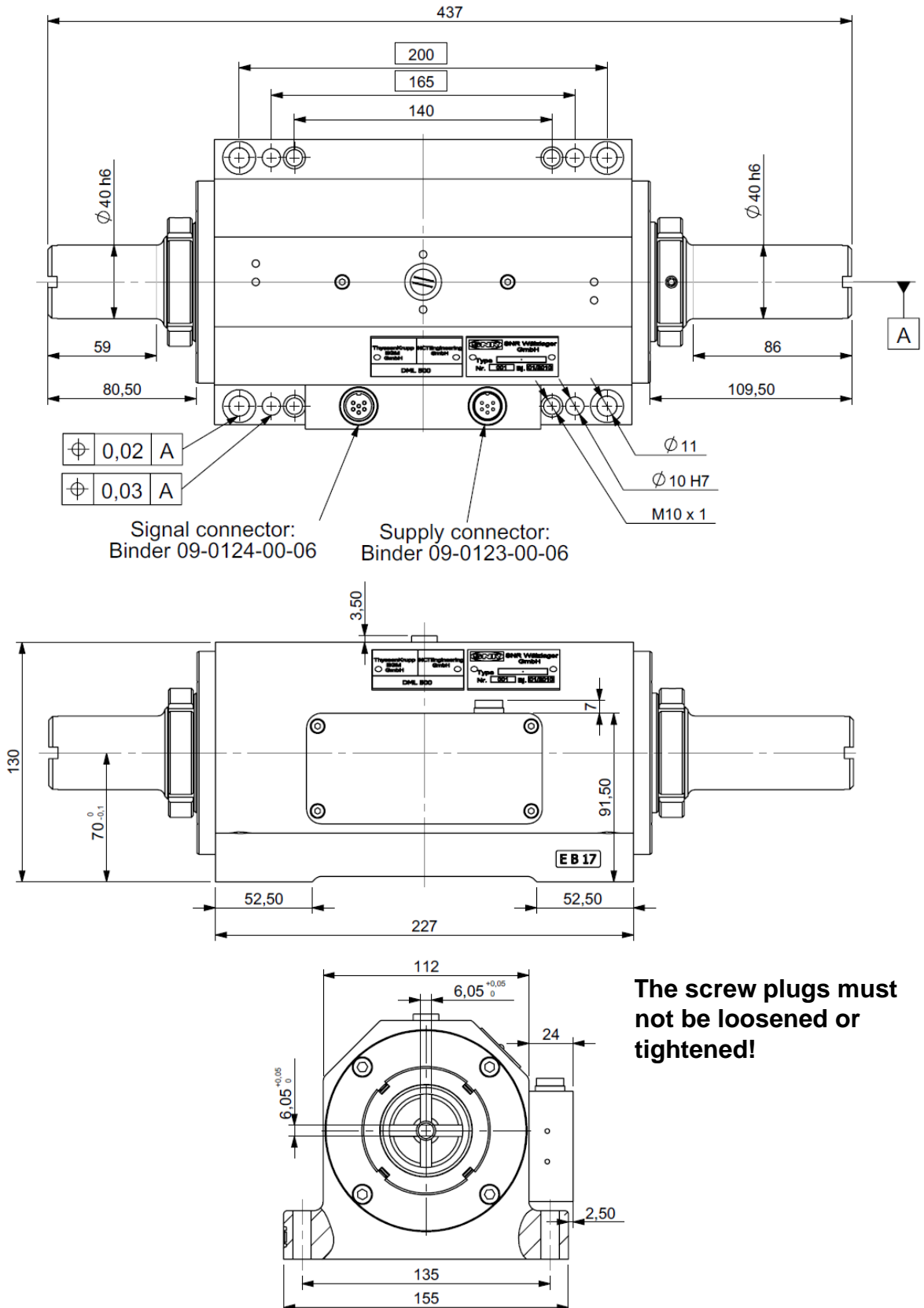

5. Allowed loads

No.	Exemplary load spectrum ¹⁾ Load values	Unit	Value
49	Average speed of rotations	rpm	2,500
50	Axial force	N	500
51	Radial force (middle of right shaft extension)	N	200
52	Radial force (middle of left shaft extension)	N	200
53	Torque	Nm	500
54	Durability	h	20,000

1) Load spectrums in which individual load components larger than the examples given here must be examined and approved by the manufacturer. We recommend on principle a review of the load spectrums. To this end please send all load data for intended use by email or post to:

NCTEngineering GmbH
Inselkammerstraße 10

82008 Unterhaching

Email: info@ncte.de

You are welcome to contact us via telephone on:
+49 (0) 89 66 56 19 0

No.	Absolute maximum loads	Unit	Value
55	Maximum speed of rotations	rpm	10,000
56	Maximum permissible torque without consideration of other loads	Nm	800 Nm

6. Condition Monitoring System

To monitor the operating status of the bearing unit with an integrated torque sensor, the DML 500 can be optionally equipped with the bearing guard VB 1001 from IFM Electronic. The link for this system is provided on the upper side of the bearing block. More information can be obtained on request from NCTE or by visiting www.ifm.com.

7. Clutches

For DML 500 overload protection, we recommend the use of a size 3 EAS-compact limiting clutch from Mayr. With this overload clutch, an overloading of the DML 500 due to excessive torque, which could lead to damage or the destruction of the sensor, can be avoided.

The clutches are adjusted to 650Nm if a measurement range of 500Nm is emanated and a load spectrum passing point 5 is verified.

More information on the clutches is available from NCTE or by visiting www.mayr.de.

8. Connection diagram

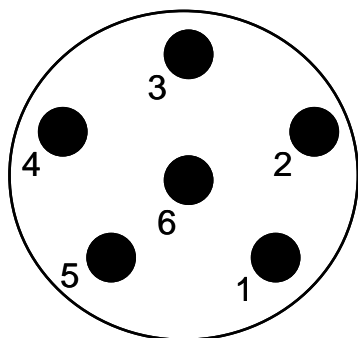

Sensor pin assignment.
Presentation: Top view
(Same for both plugs)

Supply: 6-pin		
Model: Binder DIN Stecker M16		
Item number: 09-0123-00-06		
Pin	Abbr.	Description
1	Vcc	Supply voltage +
2	GND	Ground supply voltage
3	-	not assigned
4	-	not assigned
5	-	not assigned
6	-	not assigned

Signal & communication: 6-pin		
Model: Binder DIN Stecker M16		
Item number: 09-0124-00-06		
Pin	Abbr.	Description
1	Vout	Output signal
2	VoRef	Reference ground
3	P1	Programming line 1
4	P2	Programming line 2
5	P3	Programming line 3
6	P4	Programming line 4

9. Contact



GUEMISA (Electrónica Guerra y Miró Guemisa S.L.)
Sta. Virgilia, 29 - local - 28033 Madrid (Spain)
Tlfno.: (034) 91 764 21 00 Fax.: (034) 91 764 21 32
Email.: ventas@guemisa.com Web.: www.guemisa.com