



DOCUMENTO OBSOLETO

Ver la nueva versión en
la web www.guemisa.com

novotechnik
Siedle Group

**Transducer
up to 4500 mm
touchless
absolute**

Series TLM
with Start-Stop-, SSI-,
DyMoS-, Analogue-
Interface



GUEMISA (Electrónica Guerra y Miró Guemisa S.L.)
Sta. Virgilia, 29 - local - 28033 Madrid (Spain)
Tlfn.: (034) 91 764 21 00 Fax.: (034) 91 764 21 32
Email.: ventas@guemisa.com Web.: www.guemisa.com

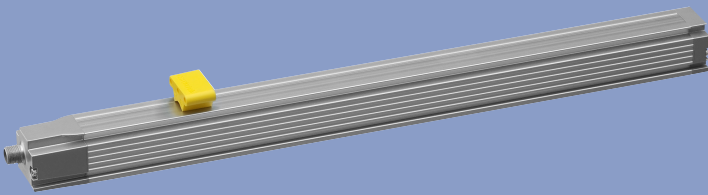

Special features

- absolute transducer, no slide arm required
- NOVOSTRICTIVE[®], touchless magnetostrictive measuring process
- high-dynamic serial DyMoS[®]-interface with data transmission interface
- non-contacting guiding with floating position marker
- unlimited mechanical life
- no velocity limit for position marker
- outstanding linearity performance up to 30 µm
- resolution up to 0.001 mm regardless of stroke length
- analogue interfaces with teach-in function
- low temperature coefficient <20 ppm/K
- insensitive to shock and vibration
- optionally cable or plug connection
- protection class IP67 / IP68

Transducers employing the NOVOSTRICTIVE[®] touchless magnetostrictive measuring process for direct, precise and absolute measurement of linear position in control, positioning and measuring technology.

The measurement is accomplished using a passive position marker which can be moved as a free-floating or guided element.

Side coupling of the position marker reduces the installation envelope size, prevents the pump effect of slide arms and permits stroke lengths up to 4500 mm.

The non-contact coupling version makes installation even simpler, and the wear-free operation means unlimited mechanical life ex-

pectancy and unlimited traverse speed of the position marker.

The temperature coefficient of the transducer is extremely low thanks to the measuring principle, design and selected materials.

The high mechanical ruggedness of the transducer combined with the underlying measuring technique mean that the system is highly resistant to shock and vibration.

The active sensing element is encased in an aluminum housing rated to IP 67. This makes the transducer resistant to contamination, dust, moisture and oils.

Mounting is accomplished using clamps that allow precise mechanical adjustment.

A sophisticated ASIC in the transducer provides for standard absolute output signals. In addition to the familiar interfaces such as the synchronous serial interface (24 or 25 bits), the Start/Stop pulse interface and analogue voltage or current interfaces, a high-dynamic serial DyMoS[®] interface with data transfer monitoring is offered.

The advantages of conventional interfaces and bus interfaces have been combined in this Novotechnik DyMoS[®] interface. In addition to the position value, the DyMoS[®] interface also allows the actual traverse velocity to be sent.

The pulse interface also allows fully tolerated processing of both edges of the Start/Stop signal.

As an option, the transducer can also be operated with multiple position markers.

Additional interfaces see separate data sheet.

Description

Housing	Anodized aluminium with metal end cap
Mounting	Compression clamps, longitudinally adjustable
Position marker	Floating marker, plastic Guided marker, ball coupling
Measuring technique	NOVOSTRICTIVE [®] , touchless magnetostrictive
Electrical connection	8-pin round connector, shielded, M12x1 8-pin round connector, shielded, IEC130-9 8-conductor cable, shielded, 1 m long
Electronics	Integrated SMD with ASIC Connect cable shield to housing

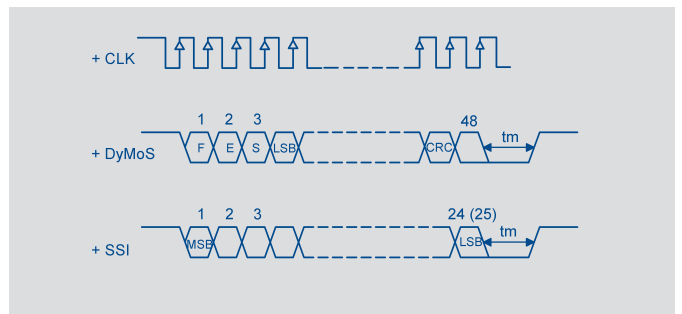
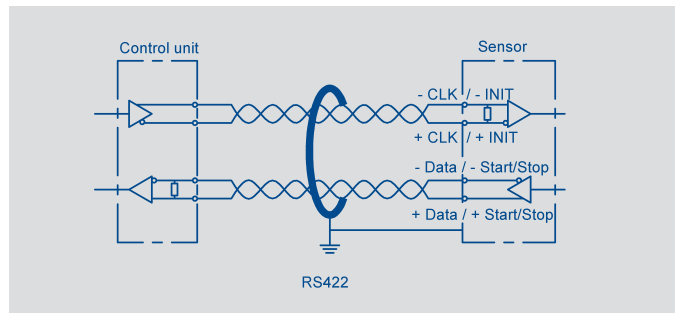
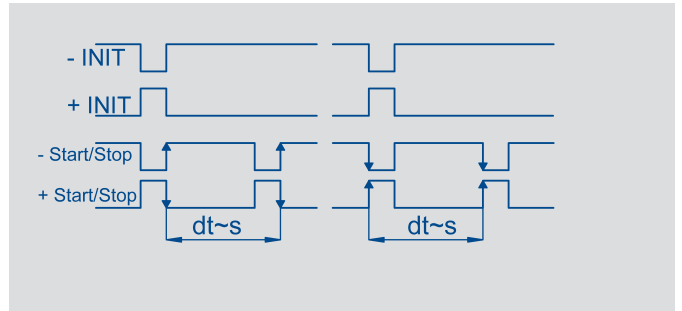
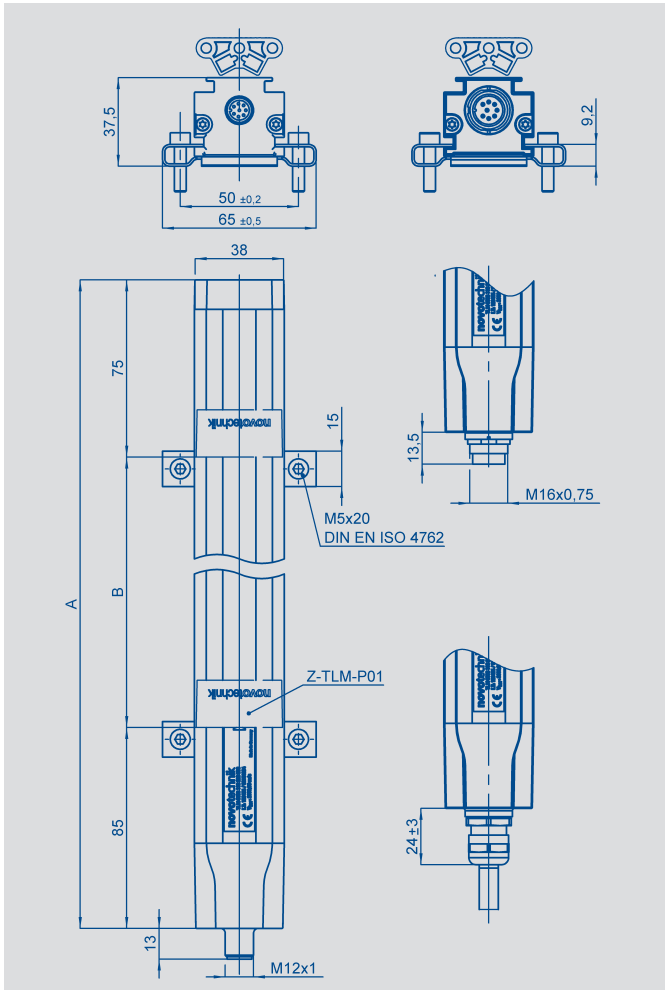

Connector pin code 101, 102	Cable colors code 201, 203, 205	Connector with cable EEM33-86, EEM33-87	Start-Stop pulse interface	SSI interface	DyMoS [®] interface	Analogue interfaces
PIN 1	YE	WH	+ INIT	+ Clk	+ Clk	0(4)...20 mA
PIN 2	GY	BN	+ Start/Stop	+ Data	+ Data 1	Signal GND
PIN 3	PK	GN	- INIT	- Clk	- Clk	+10 ... 0 (-10) VDC
PIN 4	RD	YE	open	open	- Data 2	open
PIN 5	GN	GY	- Start/Stop	- Data	- Data 1	0 (-10) ... +10 VDC
PIN 6	BU	PK	supply voltage GND	supply voltage GND	supply voltage GND	supply voltage GND
PIN 7	BN	BU	+24 VDC	+24 VDC	+24 VDC	+24 VDC
PIN 8	WH	RD	open	open	+ Data 2	open

Additional interfaces see separate data sheets.

The unipolar analogue interfaces includes standard teach-in function via the electrical connection.

Type designations	TLM xxxx 001 1xx xxx Start-Stop pulse interface	TLM xxxx 001 2xx xxx Synchronous serial interface	TLM xxxx 001 3xx xxx DyMoS® interface	Analogue interfaces	
Electrical Data					
Defined electrical range (dimension B)	from 0050 to 4500	from 0050 to 4500	from 0050 to 4500	from 0050 to 4500	mm
Absolute linearity	≤ ± 50 µm	≤ ± 30 µm	≤ ± 30 µm	≤ ± 0,02 % (min. ± 50 µm)	
Output signal	impuls	digital	digital	0.1 ... 10 VDC (load ≥10 kΩ) -10 ... 10 VDC (load ≥10 kΩ) 0.1 ... 20 mA (burden ≤500Ω) 4 ... 20 mA (burden ≤500Ω)	
Resolution	≤ 2 µm	≤ 1 digit	≤ 1 digit	≤ 0,01 %	
Reproducibility	≤ 6 µm	≤ 2 digits	≤ 2 digits	≤ 0,02 %	
Hysteresis	≤ 4 µm	≤ 1 digit	≤ 1 digit	≤ 0,01 %	
Supply voltage	24 ± 20 % reverse polarity protected	24 ± 20 % reverse polarity protected	24 ± 20 % reverse polarity protected	24 ± 20 % reverse polarity protected	VDC
Supply voltage ripple	max. 10 %	max. 10 %	max. 10 %	max. 10 %	Vpp
Current draw	≤ 100 typical	≤ 100 typical	≤ 100 typical	≤ 100 typical	mA
Output update rate	16	16	16	≤ 16	KHz
Shielding	connected to housing	connected to housing	connected to housing	connected to housing	
Temperature coefficient	≤ 20	≤ 20	≤ 20	30	ppm/K
Overvoltage protection	40 (Transzorb protection diodes)	40 (Transzorb protection diodes)	40 (Transzorb protection diodes)	40 (Transzorb protection diodes)	VDC
Reverse voltage	yes	yes	yes	yes	
Insulation resistance (500 V, 1 bar, 2 s)	≥ 10	≥ 10	≥ 10	≥ 10	MΩ
Mechanical Data					
Dimensions	see drawing	see drawing	see drawing	see drawing	
Physical length (dimension A)	Dimension B + 160	Dimension B + 160	Dimension B + 160	Dimension B + 160	± 2 mm
Environmental Data					
Operating temperature range	-40...+85	-40...+85	-40...+85	-40...+85	°C
Storage temperature range	-40...+100	-40...+100	-40...+100	-40...+100	°C
Operating humidity range	0...100	0...100	0...100	0...100	%R.H.
Shock per DIN IEC68T2-27	100 (11 ms)	100 (11 ms)	100 (11 ms)	100 (11 ms)	g
Vibration per DIN IEC68T2-6	20 (5...2000 Hz, A _{max} = 0,75 mm)	20 (5...2000 Hz, A _{max} = 0,75 mm)	20 (5...2000 Hz, A _{max} = 0,75 mm)	20 (5...2000 Hz, A _{max} = 0,75 mm)	g
Protection class per DIN 40050 IEC 529	IP67 with fastened connector IP68 with cable connection	IP67 with fastened connector IP68 with cable connection	IP67 with fastened connector IP68 with cable connection	IP67 with fastened connector IP68 with cable connection	
Mechanical data when used with unguided position marker					
Traverse speed of position marker	unlimited	unlimited	unlimited	unlimited	ms ⁻¹
Traverse acceleration of position marker	unlimited	unlimited	unlimited	unlimited	ms ⁻²
Life	unlimited (mechanical)	unlimited (mechanical)	unlimited (mechanical)	unlimited (mechanical)	move- ments
Standard defined electr. range (dimension B)	0050 up to 1000 in 50 mm steps, 1000 up to 2000 in 100 mm steps, 2000 up to 4500 in 250 mm steps; other lengths in 10 mm steps on request				
CE-conformity					
Emissions	RF noise field strength EN 55011 Group 1 Class A				
Noise immunity	ESD EN 61000-4-2 Radiated immunity EN 61000-4-3 BURST EN 61000-4-4 Conducted disturbances induced by RF fields EN 61000-4-6				

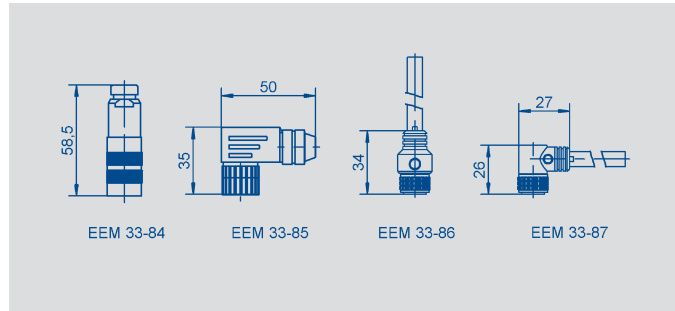
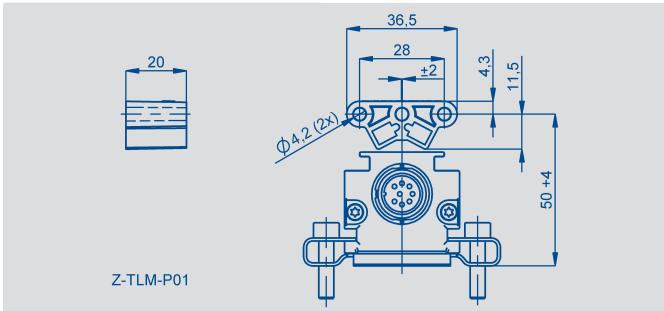

Ordering specifications

Electr. Interface

- 1: Impuls Interface, supply voltage 24 VDC $\pm 20\%$
- 2: Synchronous Serial Interface, supply voltage 24 VDC $\pm 20\%$
- 3: DyMoS[®]-Interface, supply voltage 24 VDC $\pm 20\%$
- 4: Analogue Interface, supply voltage 24 VDC $\pm 20\%$

Output signal Impuls Interface 1XX

- 1: Start Stop Signal (P) (M)
- 2: Measuring time / impuls range (L)

Output signal Synchronous Serial Interface 2XX

- 1: 24 Bit
- 2: 25 Bit

Output signal DyMoS[®] Interface 3XX

- 1: Pos. 1 + Vel. 1
- 2: Pos. 1 + Pos. 2
- 3: (Pos. 1 + Vel. 1) and (Pos 2 + Vel.2) two channel

Output signal Analogue Interface 4XX

- 1: Voltage output
- 2: Current output

Impuls Interface Start Stop Signal 11X

- 4: Variable for 1 to 3 PG

Impuls Interface measuring time / impuls range 12X

- 1: Standard

Synchronous Serial Interface 2XX

- 1: Binary Code, resolution 5 μm
- 2: Gray Code, resolution 5 μm

DyMoS[®] Interface 3XX

- 1: Binary Code, resolution 5 μm

Analogue Interface voltage output 41X

- 1: 0 VDC...10 VDC and 10 VDC...0 VDC
- 2: 0 VDC...10 VDC (Pos. 1 + Pos. 2)
- 3: -10 VDC...+10 VDC, +10 VDC...-10 VDC

Analogue Interface current output 42X

- 1: 0 mA...20 mA
- 2: 20 mA...0 mA
- 3: 4 mA...20 mA
- 4: 20 mA...4 mA

Electrical connection

- 101: 8 pin round connector IEC130-9
- 102: 8 pin round connector M 12x1
- 201: NT standard cable 1 m
- 203: NT standard cable 3 m
- 205: NT standard cable 5 m

T L M 0 8 0 0 0 0 1 1 1 4 1 0 2

Series

Defined electr. range
Several standard lengths
from 0050 to 4500 mm

Mech. configuration
001: Profile design

Included in delivery

Mounting clamps Z46, electrically isolating incl. fillister head screws

Required accessories

Floating position marker
Z-TLM-P01, Art.No. 005651;
Z-TLM-P04, Art.No. 005654;
Guided position marker
Z-TLM-P05, Art.No. 005655;
Other pos. marker on request

Recommended accessories

Connector IEC 130-9, EEM 33-84, IP67, Art.No. 005627;
Angled connector IEC130-9, EEM 33-85, IP67, Art.No. 005628;
Connector M12x1, 2 m cable, EEM 33-86, IP67, Art.No. 005629;
Angled connector M12x1, 2 m cable, EEM 33-87, IP67, Art.No. 005630;
Connector with longer cable length on request

Available on request

Standard cable, 10 m
Specific connectors
Other resolutions
SSI 26 Bit, SSI two-channel, Current output two-channel, Incremental interface, Field bus interface.

Important

Avoid equalizing currents in the cable shield caused by potential differences. Twisted pair cable is recommended.



GUEMISA (Electrónica Guerra y Miró Guemisa S.L.)
Sta. Virgilia, 29 - local - 28033 Madrid (Spain)
Tfno.: (034) 91 764 21 00 Fax.: (034) 91 764 21 32
Email.: ventas@guemisa.com Web.: www.guemisa.com