

Wegaufnehmer
 KL 100 – 1000
 Messlänge 10 – 100 mm
 5.000.000 Zyklen
 Leitplastik

Linear transducers
 KL 100 – 1000
 stroke length 10 – 100 mm
 5.000.000 cycles
 Conductive plastic

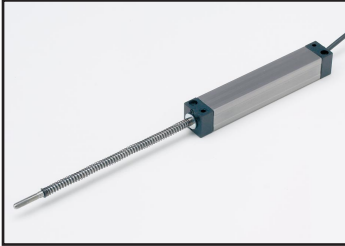

Mechanische Daten	Mechanical Data	
Querschnitt	Cross-section	13 x 13 mm
Standard-Messlängen	Standard stroke-lengths	10, 25, 50, 75 und/and 100 mm
Anschlagfestigkeit	End-stop strength	max. 200 N
Verstellkraft bei Schubstange SE	Operating force - model SE	3 N max
Verstellkraft bei Schubstange SEF	Operating force - model SEF	10 N max
Hubgeschwindigkeit	Operating speed	max. 0.1 m/s
Wiederholgenauigkeit	Repeatability	0.05 mm
Lebensdauer	Life expectancy	5.000.000 Zyklen/cycles
Elektrische Daten	Electrical Data	
Anschlusswiderstand R	Nominal resistance R	1K/5K Ω
Widerstandstoleranz	Resistance tolerance	$\pm 20 \%$
Linearität	Linearity	$\pm 1 \%$
maximaler Übergangswiderstand	Maximum contact resistance	ENR 20 K Ω
Empf. Betriebsstrom im Schleiferkreis	Recommended wiper current	<0.1 μ A
Maximaler Schleiferstrom im Störfall	Max. wiper curr. in case of malfunct.	10 mA
Belastung P	Power rating P	0.5 W/ 40°C
Maximale Anschlussspannung	Maximum supply voltage	$U_{max} = \sqrt{PxR}$
Temperaturkoeffizient Spannungsteiler	Temperature coefficient voltage divider	50 ppm/°C
Spannungsfestigkeit	Dielectric strength	700 VAC/1 min
Isolationswiderstand	Insulating resistance	10 G Ω bei/at 500 VDC
Umgebungsbedingungen	Environmental Conditions	
Lagertemperatur	Storage temperature	-25°C... +105°C
Betriebstemperatur	Operating temperature	-25°C... +75°C
Klimatische Prüfklasse	Climatic rating	25/075/56
Schutzart	Protection rating	IP 65
Vibrationen	Vibration	10 G (30 – 2000 Hz, 0.75 mm)
Schock	Shock	50 G (Halbsinus, 7 ms) 50 G (half sine pulse, 7 ms)
Material	Material	
Gehäuse	Housing	Aluminium eloxiert Anodized aluminium
Lagerung	Bearing	in Kunststoff/in plastic
Kabel	Cable	1 m PUR 3 x 0.06 mm ²

Optionen

- Linearität $\pm 0.25\%$ (KL 100 $\pm 0.5\%$)
- Widerstandswerte zwischen 1K Ω und 20K Ω
- Hublängen zwischen 10 mm und 100 mm
- Schubstange durchgehend
- Längere Schubstange
- Litzenanschluß
- Längerer Kabelanschluß
- Tandemausführung

Options

- Linearity $\pm 0.25\%$ (KL 100 $\pm 0.5\%$)
- Resistance values between 1K Ω and 20K Ω
- Stroke lengths from 10 mm to 100 mm
- Feed-through shaft
- Longer shafts
- Lead connections
- Longer cable
- Redundant signal

Typ	Model	KL 100 SE	KL 250 SE	KL 500 SE	KL 750 SE	KL 1000 SE
Anschlussbild	Connecting diagram	1	1	1	1	1
Massbild	Dimension drawing	A	A	A	A	A
Elektr. Hublänge in mm	Electr. stroke length in mm	10	25	50	75	100
Abmessungen in mm	Dimensions in mm					
A		68.5	98.5	148.5	198.5	248.5
B		42	57	82	107	132
C		26.5	41.5	66.5	91.5	116.5
D		58.5	73.5	98.5	123.5	148.5
E		35	50	75	100	125

SE = Schubstange einseitig
SE = Single-ended shaft version

Anschlussbild
Connecting diagram

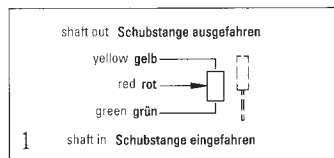

Massbild
Dimension drawing

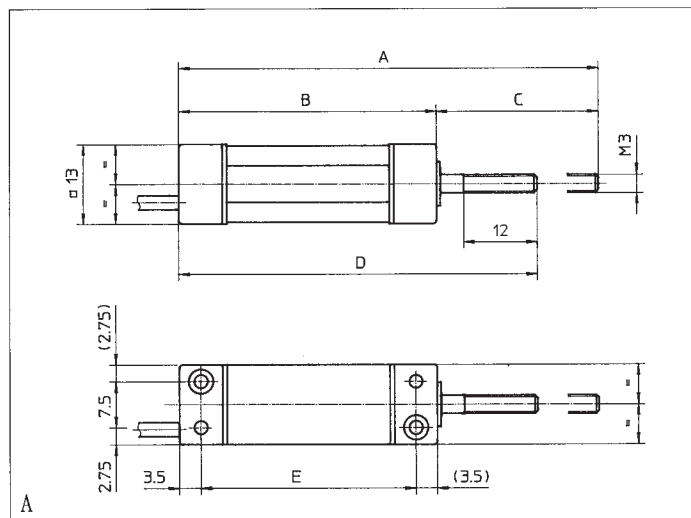

Wegaufnehmer
 KL 100 – 1000
 Messlänge 10 – 100 mm
 5.000.000 Zyklen
 Leitplastik

Linear transducers
 KL 100 – 1000
 stroke length 10 – 100 mm
 5.000.000 cycles
 Conductive plastic

Typ	Model	KL 100 SEF	KL 250 SEF	KL 500 SEF
Anschlussbild	Connecting diagram	1	1	1
Massbild	Dimension drawing	B	B	B
Elektr. Hublänge in mm	Electr. stroke length in mm	10	25	50
Abmessungen in mm	Dimensions in mm			
A		77.5	117.5	177.5
B		42	57	82
C		35.5	60.5	95.5
D		67.5	92.5	127.5
E		35	50	75

SEF = Schubstange einseitig mit Feder
 SEF = Single ended shaft, with return spring

Anschlussbild
 Connecting diagram

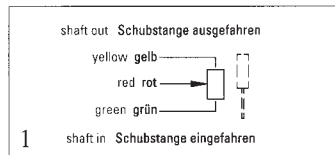

Massbild
 Dimension drawing

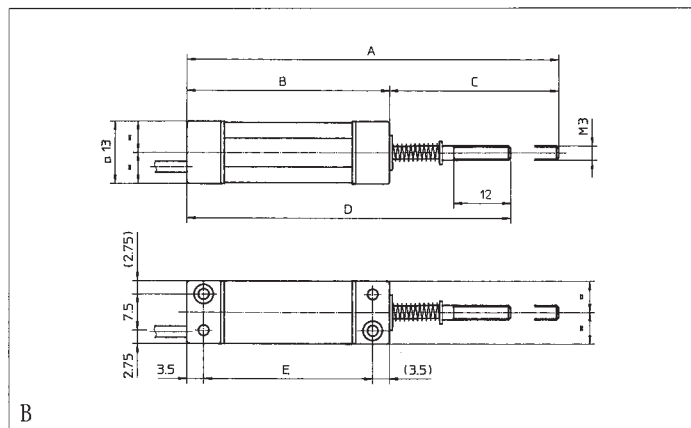

Typ	Model	KL 100 SEZN	KL 250 SEZN	KL 500 SEZN	KL 750 SEZN	KL 1000 SEZN
Anschlussbild	Connecting diagram	1	1	1	1	1
Massbild	Dimension drawing	C	C	C	C	C
Elektr. Hublänge in mm	Electr. stroke length in mm	10	25	50	75	100
Abmessungen in mm	Dimensions in mm					
A		78.5	108.5	158.5	208.5	258.5
B		42	57	82	107	132
C		36.5	51.5	76.5	101.5	126.5
D		68.5	83.5	108.5	133.5	158.5
E		35	50	75	100	125

SE = Schubstange einseitig SE = Single ended shaft version
Z = Zentralbefestigung Z = Bush mounting
N = M6 x 0.75 N = M6 x 0.75

Anschlussbild
Connecting diagram

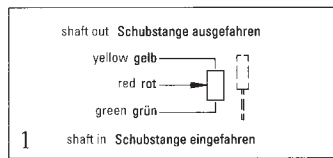

Massbild
Dimension drawing

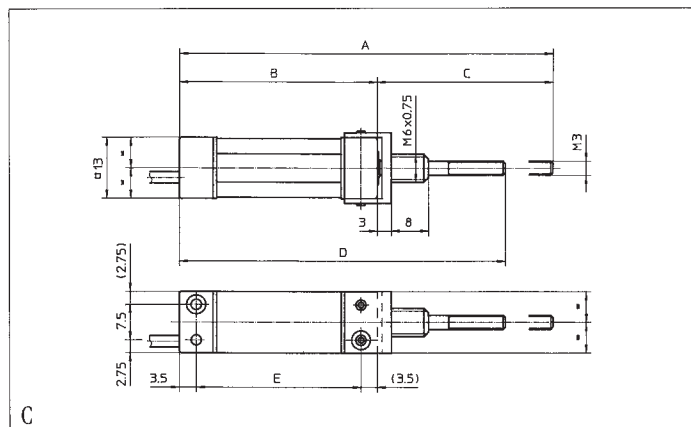

Wegaufnehmer
KL 100 – 1000
Messlänge 10 – 100 mm
5.000.000 Zyklen
Leitplastik

Linear transducers
KL 100 – 1000
stroke length 10 – 100 mm
5.000.000 cycles
Conductive plastic

Typ	Model	KL 100 SEZM	KL 250 SEZM	KL 500 SEZM	KL 750 SEZM	KL 1000 SEZM
Anschlussbild	Connecting diagram	1	1	1	1	1
Massbild	Dimension drawing	D	D	D	D	D
Elektr. Hublänge in mm	Electr. stroke length in mm	10	25	50	75	100
Abmessungen in mm	Dimensions in mm					
A		75.2	105.2	155.2	205.2	255.2
B		41.7	56.7	81.7	106.7	131.7
C		33.5	48.5	73.5	98.5	123.5
D		65.2	80.2	105.2	130.2	155.2

SE = Schubstange einseitig
 Z = Zentralbefestigung
 M = M10 x 0.75

SE = Single ended shaft version
 Z = Bush mounting
 M = M10 x 0.75

Anschlussbild
Connecting diagram

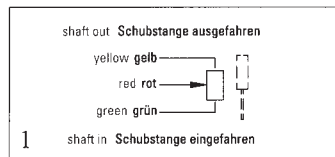

Massbild
Dimension drawing

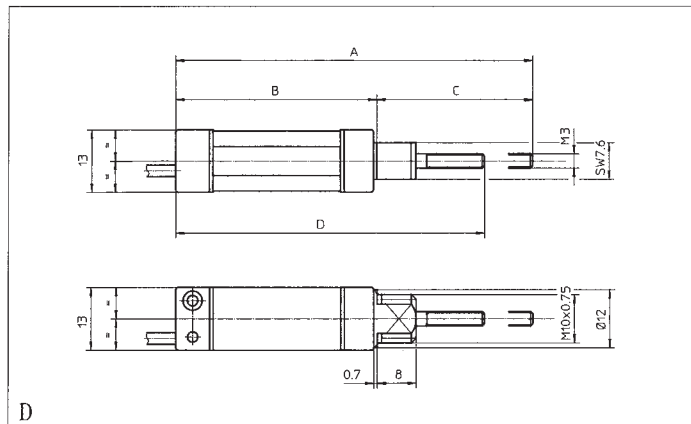

Typ	Model	KL 100 SEFZN	KL 250 SEFZN	KL 500 SEFZN
Anschlussbild	Connecting diagram	1	1	1
Massbild	Dimension drawing	E	E	E
Elektr. Hublänge in mm	Electr. stroke length in mm	10	25	50
Abmessungen in mm	Dimensions in mm			
A		88.5	128.5	188.5
B		42	57	82
C		46.5	71.5	106.5
D		78.5	103.5	138.5
E		35	50	75

SEF = Schubstange einseitig mit Feder
Z = Zentralbefestigung
N = M 6 x 0.75

SEF = Single ended shaft, spring return version
Z = Bush mounting
N = M 6 x 0.75

Anschlussbild

Connecting diagram

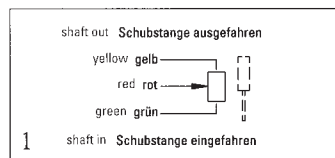

Massbild

Dimension drawing

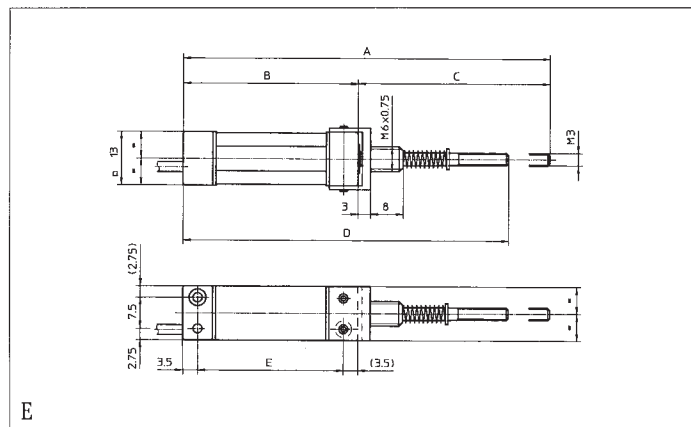

Typ	Model	KL 100 SEFZM	KL 250 SEFZM	KL 500 SEFZM
Anschlussbild	Connecting diagram	1	1	1
Massbild	Dimension drawing	F	F	F
Elektr. Hublänge in mm	Electr. stroke length in mm	10	25	50
Abmessungen in mm	Dimensions in mm			
A		85.2	125.2	185.2
B		41.7	56.7	81.7
C		43.5	68.5	103.5
D		75.2	100.2	135.2

SEF = Schubstange einseitig mit Feder
Z = Zentralbefestigung
M = M 10 x 0.75

SEF = Single ended shaft, with return spring
Z = Bush mounting
M = M 10 x 0.75

Anschlussbild
Connecting diagram

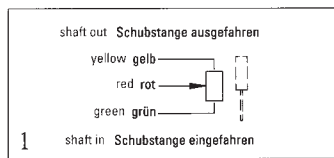

Massbild
Dimension drawing

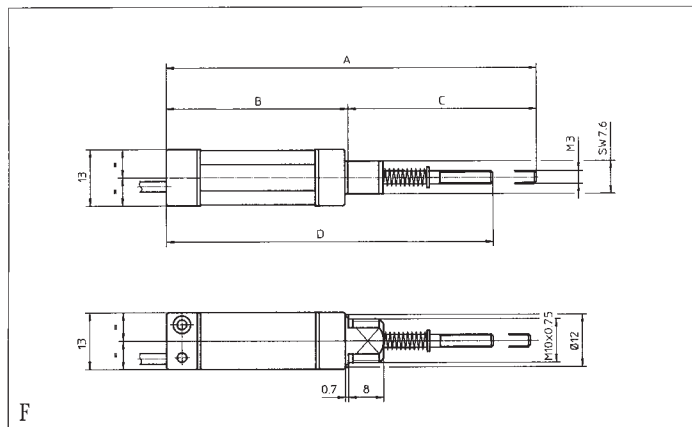

Zubehör/Massbilder
Accessories/Dimension Drawings

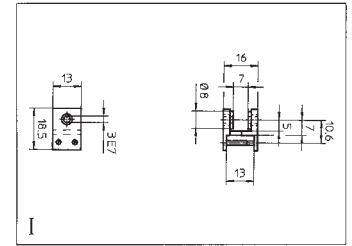
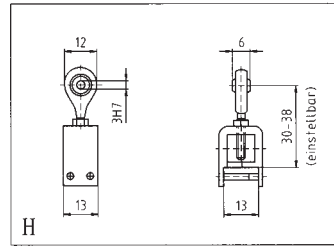
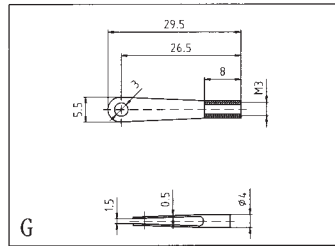
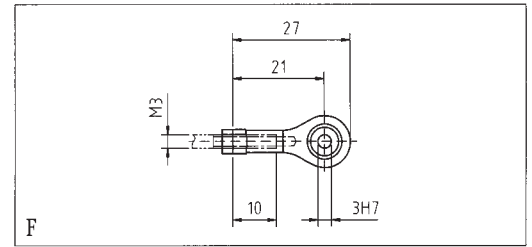
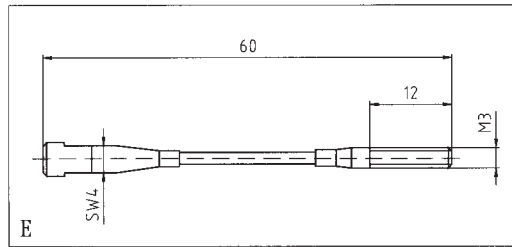

Art. Nr.	Typ	Bezeichnung	Bemerkung
Art. No.	Model	Marking	Remarks
70800	ZK-E 060	Elast. Ankopplung zum Ausgleich v. Winkelversatz	siehe Zeichnung E
70800	ZK-E 060	Elastic coupling to balance angular displacement	Drawing E
82289	ZK-G	Gelenkstangenkopf m. Gleitlager u. M3 Innengewinde	siehe Zeichnung F
82289	ZK-G	Rod End Bearing with M3 internal thread, inox	Drawing F
82290	ZK-S	Gabelstangenkopf mit M3 Innengewinde	siehe Zeichnung G
82290	ZK-S	Fork Coupling with M3 internal thread, inox	Drawing G
82228	ZK-A	Aluminium-A-Profil	siehe Zeichnung H
82228	ZK-A	Aluminium-A-Profile	Drawing H
82291	ZK-H	Aluminium-H-Profil	siehe Zeichnung I
82291	ZK-H	Aluminium-H-Profile	Drawing I
82292	ZK-M	Tastspitze	siehe Zeichnung J
82292	ZK-M	Gauging tip	Drawing J
82293	ZK-K	Hutmutter M3 für einfache Tastfunktionen	siehe Zeichnung K
82293	ZK-K	Acorn nut for simple gauging operations	Drawing K

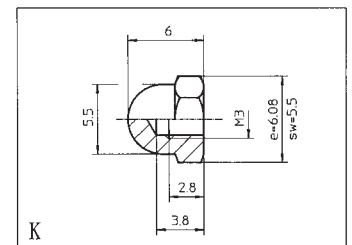
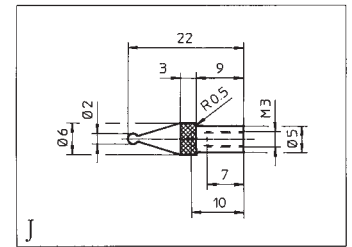

Sta. Virgilia 29 Local.1A 28033 Madrid
Tfno.: 91 764 21 00 Fax.: 91 764 21 32
www.guemisa.com Email.:info@guemisa.com