



Reaction torque transducer type 0150 RD

Application:

The construction was optimized concerning the length, weight and volume, to minimize axial forces and bending load on the measuring element.

For special measuring assignments, the construction of our torque transducers can also be adjusted to the respective applications.



Torque transducer type 0150 RD

General information:

Reaction torque transducers type 0150 RD are used for static and quasi-static applications.

By that way a maintenance-free torque measuring is possible.

The applications are used for adjusting torque at machine elements, measuring of stirring devices and checking motors as well as hydraulic pumps. These models are suitable for all flange mounting situations.

Special features:

- Nominal range 10 Nm to 10 000 Nm
- Accuracy 0,2 % of full scale
- Solid and robust
- Easy to handle
- Compact design

Example of order:

Data sheet	Nominal torque	part#
0150	10 Nm	16594
	25 Nm	17445
	50 Nm	17446
	100 Nm	17447
	200 Nm	17448
	500 Nm	17451
	1000 Nm	17452
	2000 Nm	21054
	5000 Nm	21055
	10000 Nm	21481
	>10000 Nm	on request

Example: 0150 - 100 - 17447

Technical data:

Rated output:	1 mV/V
Bridge resistance:	350 Ω, nominal
Excitation:	5 .. 12 V DC
Linearity and hysteresis to assemble:	≤ ± 0,2 % f.s.
Temperature influence on the zero point:	± 0,01 % f.s./K
Temperature influence on nominal value:	± 0,01 % f.s./K
Nominal temperature range:	- 5 ... +45°C
Operating temperature range:	- 15 ... +55°C
Relative span length:	≤ ± 0,01 % f.s.
Overload capacity:	150 % of nominal range
Rupture torque:	> 300 % of nominal range
Dynamic performance:	70 % of capacity
Protection class:	IP 45

Mechanical dimensions:

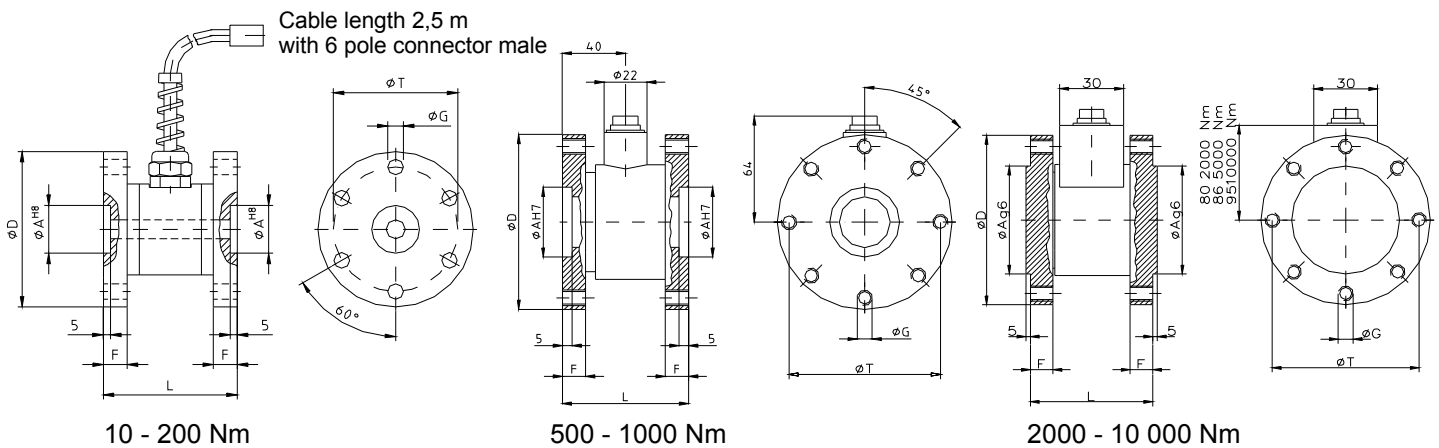

Nominal torque in Nm	Dimensions [mm]						Numbers of holes of T	Article no. part#	fastening torque for assembly Nm
	L	φD	F	φA	φT	G			
0 ... ± 10	65	70	12	20 ^{H7}	58	M 8	6 x 60°	16594	1,5
0 ... ± 25	65	70	12	20 ^{H7}	58	M 8	6 x 60°	17445	3
0 ... ± 50	65	70	12	20 ^{H7}	58	M 8	6 x 60°	17446	6
0 ... ± 100	65	70	12	20 ^{H7}	58	M 8	6 x 60°	17447	12
0 ... ± 200	65	70	12	20 ^{H7}	58	M 8	6 x 60°	17448	20
0 ... ± 500	80	100	15	40 ^{H7}	82	M 10	8 x 45°	17451	35
0 ... ± 1000	80	100	15	40 ^{H7}	82	M 10	8 x 45°	17452	70
0 ... ± 2000	110	150	20	70 ^{G6}	120	M 12	6 x 60°	21054	110
0 ... ± 5000	140	250	25	100 ^{G6}	220	M 12	8 x 45°	21055	150
0 ... ± 10000	180	280	35	180 ^{G6}	240	M 18	8 x 45°	21481	250

> 10000 Nm on request

Electrical connecting:

PIN 1	-	Excitation	PIN 4	+	output signal
PIN 2	+	Excitation	PIN 5	-	output signal
PIN 3		shield (open)	PIN 6		100% calibration signal

Mating connector 6-pin connector, female Part# 822, (Binder type: 99-2022.09-6)