

SENSORES DE pH

Epoxy y cristal

DPF
sensors



Robustez y facilidad de manejo, bajo mantenimiento, no precisan relleno de electrolito.

Diagrama interno para la protección del elemento de referencia frente a contaminaciones.

Disponemos de sensores para todo tipo de aplicación, aguas puras, piscinas, aguas muy contaminadas, equipos portátiles, uso en laboratorios, alta temperatura y presión, agricultura, etc...

Electrodos pH cuerpo en epoxi

Electrodos para pH combinados de vidrio/ referencia gel, en plástico.



SZ 142: Cable de 1,5 metros con conector BNC tipo Phoenix 2732526.005B

Aplicación en: Aguas limpias, instrumentos portátiles y piscinas.

SZ 145: Cable de 9 metros con conector BNC tipo Phoenix 2732526.005B

Aplicación en: Aguas limpias a temperatura ambiente, uso industrial hasta 7 bar.

SZ 1021: Cable de 1 metro con conector BNC, bajo coste

Aplicación en: Equipos portátiles (10 unid. pedido mínimo).

SZ 1025: Cable de 9 metros, bajo coste
Aplicación en: Aguas limpias a temperatura ambiente, uso industrial hasta 7 bar. (10 unid. pedido mínimo)



SZ 151: Doble combinación, cable de 1,5 metros con conector BNC.

Aplicación en: Aguas muy contaminadas o alta temperatura.



SZ 1075: Electrodo de antimonio, cable de 9 metros

Aplicación en: Líquidos ácidos con HF (requiere controlador pH 7685.010)



SZ 1093: Electrodo pH hidropónico, longitud 85 mm, cable de 3 metros con conector BNC.

Aplicación en: Invernaderos, agricultura y uso industrial en línea hasta 7 bar.



SZ 1131: Sensor pH para pinchar, diafragma de PTFE, cable de 1 metro con conector BNC.

Aplicación en: Invernaderos, agricultura.

SENSORES DE pH

Epoxy y cristal

DPF
sensors

Electrodos pH cuerpo en cristal

Electrodos para pH combinados de vidrio/ referencia gel, cuerpo en cristal.



SZ 160: Combinación cristal/ referencia, cuerpo de cristal, ranura anular, con conector coaxial S7.

Aplicación en: líquidos contaminados, instrumentos portátiles, laboratorios.



SZ 171: Combinación cristal/ referencia, cuerpo de cristal, doble ranura anular, cable de 1,5 metros con conector BNC.

Aplicación en: Líquidos contaminados, instrumentos portátiles, uso industrial.

SZ 173: Combinación cristal/ referencia, cuerpo de cristal, doble ranura anular, cable de 9 metros.

Aplicación en: Líquidos contaminados, uso industrial en línea hasta 10 bar de presión y condiciones extremas.



SZ 1031: Combinación rellenable de cristal/ referencia, cuerpo de cristal, cable de 1,5 metros con conector BNC.

Aplicación en: Líquidos muy contaminados, instrumentos portátiles, laboratorio.



SZ 161: Combinación cristal/ referencia, cuerpo de cristal, ranura anular, cable de 1,5 metros con conector BNC.

Aplicación en: Líquidos contaminados, instrumentos portátiles, laboratorio. Presión en línea hasta 10 bar.

SZ 165: Combinación cristal/ referencia, cuerpo de cristal, ranura anular, cable de 9 metros.

Aplicación en: Uso general, uso industrial hasta 10 bar de presión.



SZ 191: Combinación cristal/ referencia, cuerpo de cristal, doble ranura anular con Gel para alta temperatura, cable de 1,5 metros con conector BNC.

Aplicación en: Líquidos alta temperatura, OEM.

SZ 195.1: Combinación cristal/ referencia, cuerpo de cristal, bulbo en cúpula, doble ranura anular, bajo error alcalino, cable de 9 metros.

Aplicación en: Líquidos contaminados y alta temperatura, uso industrial en línea hasta 10 bar de presión y condiciones extremas.

Electrodos pH autolimpiables

Estos electrodos son la nueva generación de los tradicionales electrodos lisos, que mantienen las características autolimpiantes por el efecto del flujo tangencial del fluido.

Pueden utilizarse en tubería o sumergidos.

Electrodo doble con electrolito sellado, no necesita mantenimiento y garantiza un prolongado funcionamiento con líquidos que contienen amoníaco, cloro, sulfatos, cianatos y otros contaminantes.



SZ 1140: Gel polímero, rango 0...12 pH, temperatura de uso 0.. 100 °C, máxima presión 10 bar, cuerpo de PVDF, conector tipo DL, rosca 3/4" NPT, longitud de 140 mm (45 mm sumergidos)

Cable: accesorio **SZ 947** con 9 metros.



SZ 1150: Gel polímero, con sensor Pt 100, rango 0...12 pH, temperatura de uso 0...100 °C, máxima presión 10 bar, cuerpo de PVDF, conector tipo DL, rosca 3/4" NPT, longitud de 140 mm (45 mm sumergidos), cable: accesorio **SZ 9441** con 10 metros y conector IP67

ORP autoclean flat electrodes



SZ 2060
 ORP electrode, double junction, polymeric gel.
 Electrode: Platinum disk
 Temperature: 0/100 °C
 Pressure: 10 bar
 Body: in PVDF, DL connector, 3/4" NPT thread
 Length: 140 mm (45 mm in immersion)
 Cable: SZ 947, L=8 m (not included)

Epoxy O.R.P. electrodes



SZ 240 Gold/Reference combination electrode. Sealed Gel, epoxy body, S7 connector.

Applications: clean water, portable instruments, laboratory.

SZ 250 Platinum/Reference combination electrode. Sealed Gel, epoxy body, S7 connector.

Applications: clean water, portable instruments, laboratory.



SZ 245 Gold/Reference combination electrode. Sealed Gel, epoxy body, cable 9 m.

Applications: cyanide treatment, industrial instruments.
 In-line up to 7 bar.



SZ 2011 Platinum wire/Reference combination electrode. Sealed Gel, epoxy body, cable 1.5 m with BNC connector.

O.E.M. low cost version. (10 pcs. minimum order)

Applications: Swimming pools, portable and industrial instruments. In-line up to 7 bar.



SZ 2055 Platinum/Reference combination electrode. Sealed Gel, epoxy body, cable 9 m, bulk.

O.E.M. low cost version. (10 pcs. minimum order)

Applications: clean water, swimming pools, industrial instruments. In-line up to 10 bar.



SZ 251 Platinum/Reference combination electrode. Sealed Gel, epoxy body, cable 1.5 m with BNC connector.

Applications: clean water, swimming pools, portable instruments, laboratory. In-line up to 7 bar.

SZ 255 Platinum/Reference combination electrode. Sealed Gel, epoxy body, cable 9 m.

Applications: clean water, swimming pools, industrial instruments. In-line up to 7 bar.

SZ 2035 ORP electrode Band-Platinum/Ref. combination, epoxy body, Gel sealed, cable 9 m. Low cost (10 pcs minimum order).

Applications: clean water, industrial instruments.
 In-line up to 7 bar.

Glass O.R.P. electrodes



SZ 265 Gold/Reference combination electrode. Sealed Gel, glass body, cable 9 m.

Applications: cyanide treatment, industrial instruments.
 In-line up to 10 bar.



SZ 275 Platinum/Reference combination electrode. Sealed Gel, glass body, cable 9 m.

Applications: general purpose, chromate treatment, swimming pools, industrial instruments. In-line up to 10 bar.

Specifications

Type	Metal	Temperature °C	Length mm	Diameter mm	Reference
SZ 240	Gold	0 / 60	110	12	Ag/AgCl
SZ 245	Gold	0 / 60	110	12	Ag/AgCl
SZ 250	Platinum	0 / 60	110	12	Ag/AgCl
SZ 251	Platinum	0 / 60	110	12	Ag/AgCl
SZ 255	Platinum	0 / 60	110	12	Ag/AgCl
SZ 2035	Platinum	0 / 60	110	12	Ag/AgCl
SZ 265	Gold	-5 / 110	110	12	Ag/AgCl
SZ 275	Platinum	-5 / 110	110	12	Ag/AgCl
SZ 2011	Platinum	0 / 60	110	12	Ag/AgCl
SZ 2055	Platinum	-5 / 130	110	12	Ag/AgCl + KNO3

SENSORES DE pH Y O.R.P.

Controladores

DPF
sensors

PH 7685

pH/ORP controller



Add the following to the common Features/Specifications of the 7685 Series shown overleaf

- Applications:
 - water treatment
 - food industry
 - drinking water
 - swimming pool
 - biotechnology
- Temperature readout
- Calibration parameters display
- Set-point and alarm conditions display
- Automatic or manual Temperature compensation
- Operating mode: automatic and manual
- 0/20 mA or 4/20 mA programmable isolated output
- Dual set-points with hysteresis, delay and min/max programmable functions
- Min/max and set-points timing alarm relay
- EEPROM parameter storage
- Automatic overload protection and reset
- Extractable terminal blocks
- 96X96 (1/4" DIN) housing

Specifications

Sensors type
Glass pH - Antimony pH - ORP - 080102 preamplifier
RTD Pt 100 3 wires

Glass electrode
Zero: 0.0 mV at pH 7 ± 2 pH adjustment
Slope: 59.16 mV/pH at 25 °C 80/110 % adjustment

Antimony electrode
Zero: -325 mV at pH 7 ± 2 pH adjustment
Slope: 50 mV/pH at 25 °C 70/140 % adjustment

ORP electrode
Zero adjustment: ± 100 mV
Sens. adjustment: 80/110 %

Input scales
* pH: 0.00/14.00 ± 0.01 pH
* ORP: -1000/+1000 mV ± 1 mV
* Software filter: 0.4/50.0 s

Temperature
Measuring and compensation range: -10/+110 °C
Resolution: ± 0.1 °C
Zero adjustment: ± 2 °C
Manual Temp. comp: -10.0/110.0 °C

Option 091.211
Set-point A/B selectable actions: ON/OFF - PFM - PWM

PFM action
Proportional band: 0.00/1.50 pH (0/150 mV)
Pulse frequency: 0/120 pulse/min
Function: Min/Max

PWM action
Proportional band: 0.00/1.50 pH (0/150 mV)
Pulse Period: 0/99.9 s
Function: Min/Max

Option 091.3711
Dual isolated output.
The user may select the temperature output

The technical specifications could be changed without notice.

Accessories

This instrument may use all pH and ORP sensors and amplified probes from B&C Electronics catalogue.

SENSORES DE pH Y O.R.P.

Controladores

DPF
sensors

pH 7685.010

pH+ORP controller



Add the following to the common Features/Specifications of the 7685 Series shown overleaf

- Applications:
 - pH + ORP measuring
 - chromate and cyanide treatment plants
 - swimming pool
 - autoclean sensors
 - PFM / PWM regulations
- Dual input from:
 - pH electrode (Glass or Antimony)
 - ORP electrode
- Input from Pt100 3 wires
- pH/mV/Temperature readout
- Software filter
- Operating mode: automatic and manual
- Calibration parameters display
- Set-point and alarm conditions display
- Automatic or manual Temperature compensation
- Dual isolated output:
 - 0/20 mA or 4/20 mA selectable
 - pH/ORP/°C selectable
- Dual set-points (pH/ORP selectable) with selectable action:
 - ON/OFF
 - PFM proportional Pulse Frequency Modulation
 - PWM proportional Pulse Width Modulation with hysteresis, delay and min/max programmable functions
- Min/max and set-points timing alarm relay
- Autoclean relay
- EEPROM parameter storage
- Automatic overload protection and reset
- Extractable terminal blocks
- 96X96 (1/4" DIN) housing

Specifications

Sensor type
Glass pH/Antimony pH/ ORP

Glass electrode
Zero: 0.0 mV at pH 7 ±2 pH adjustment
Slope: 59.16 mV/pH 25 °C 80/110 % adjustment

Antimony electrode
Zero: -325 mV at pH 7 ±2 pH adjustment
Slope: 50 mV/pH 25 °C 70/140 % adjustment

ORP electrode
Zero adjustment: ±1000 mV
Sens. adjustment: 80/110 %

Input scales
* pH: 0.00/14.00 ±0.01 pH
* ORP: -1000/+1000 mV ±1 mV
* Software filter: 0.4/50.0 s

Temperature
Input: RTD Pt100 2/3 wires connection
Measuring and compensation range: -10/+110 °C
Zero adjustment: ±2 °C

Set point A and B
* ON/OFF action 0.00/14.00 pH -1000/1000 mV
Hysteresis: 0.00/1.50 pH 0/150 mV
Delay: 0.0/99.9 s
* Function: Min/Max

PFM action
Proportional band: 0.00/1.50 pH 0/150 mV
Pulse frequency: 0/120 pulse/min
* Function: Min/Max

PWM action
Proportional band: 0.00/1.50 pH 0/150 mV
Pulse Period: 0/99.9 sec
* Function: Min/Max

Relay contacts
SPDT 220 V 5 A (Resistive load)

Analog output N° 1 and N° 2
* Input corresponding to the analog output : pH/mV/°C
* Output range: 0-20/4-20 mA (it can be made to represent any segment of the measuring scale)

Option
091.701 RS 232 isolated output.
The output sends the data (pH, mV, °C) to the serial port of the computer.
091.404 24 Vac power supply

The technical specifications could be changed without notice

Accessories

This instrument may use all pH and ORP sensors from B&C Electronics catalogue.

SENSORES DE pH Y O.R.P.

Controladores

DPF
sensors

PH 565.2

pH controller

- Input from pH electrodes and microtransmitters
- Temperature display
- Manual and automatic Temperature compensation



General informations

This instrument has all the advantages of a modern and reliable pH measurement and regulation for use in industrial plants and is particularly suitable for use in fermentation processes.

Input comes directly from pH electrodes or from microtransmitters. The controller provides a digital readout of pH.

Automatic or manual Temperature compensation from 0° to 100°C is provided with the Pt 100 device.

It also features digital readings of the solution's Temperature.

The manual Temperature compensation operates when the automatic compensation is excluded (RTD non connected).

The Temperature readout, both in manual and automatic Temperature operation, is obtained by pushing a button on the front panel.

There are two independent on-off A and B regulators that are programmed by a front-panel control to trigger at any level within the range of the meter.

The two set points have the feature of being changeable by rear selectors and can be delayed up to 5 seconds.

The controller provides an output of 0/20 or 4/20 mA selectable proportional to the meter reading, for driving a recorder or remote readout having a non grounded input.

Specifications

Add the following to the common Specifications shown overleaf

Input from: pH electrode
microtransmitter mod. 080102
RTD Pt100

Scale: 0.00/14.00 pH

Temperature readout: 0/100.0 °C

Temp. compensation: automatic and manual 0/100 °C

Temperature sensor: RTD Pt100

Input Current: < 2 pA at 20 °C

Input Impedance: > 10 exp 12 ohm

MV 545.2

O.R.P. controller

- Input from O.R.P. electrodes and microtransmitters
- Scale -1.999 / 1.999 mV
- Regulators scale 0 / 1000 mV



General informations

This instrument, together with a probe and a microtransmitter, make up the most advanced system in the field of ORP measurement/regulation in industrial plants.

The controller provides a digital readout of ORP.

Input comes directly from an electrode or from a microtransmitter.

There are two independent on-off A and B regulators with the possibility of selecting the min/max function by rear selectors and also the possibility to insert a delay function from 0 to 5 Seconds for each set-point.

The controller provides an output of 0/20 or 4/20 mA selectable and proportional to the meter reading, for driving a recorder or remote readout having a non-grounded input.

Specifications

Add the following to the common Specifications shown overleaf

Input: from electrode
from microtransmitter mod. 080102

Display scale: ±1999 mV

Regulators scale: ±1000 mV (others as requested)

Input Current: < 2 pA at 20 °C

Input Impedance: > 10 exp 12 ohm

SENSORES DE pH Y O.R.P.

Controladores

DPF
sensors

3647 Models

Dual set-point

PH 3647

PH controller

- LCD Display
- Automatic Temperature Compensation
- Dual set points
- Set point values display
- HI/LO selectable limits
- Adjustable relay time delay
- 4/20 mA output
- DIN Rail mounting
- Detachable terminal block connectors

General informations

The pH controller incorporates a large LCD display which is easily readable even from considerable distances.

The controller will display set point values by depressing a button on the front panel next to the corresponding adjustment potentiometer.

The HI/LO function may be selected for each relay.

Dead Band relay adjustment allows relay activation to be delayed from 0/40 Seconds.

Automatic Temperature Compensation is achieved with use of a NTC 10K.

The 4/20 mA output is available for input into recorders or other devices requiring a 4/20 mA input signal.

Zero and sensitivity (span) calibration adjustments are located on the front panel and are easily accessible.

The controller may be powered by an external power supply 110/220 Vac.

All plastic construction provides maximum resistance to corrosion.

Detachable terminal block connectors and DIN Rail mounting provide for easy field installation.

Accessories

See Series 3000 accessories.



Specifications

Display: LCD

Input: pH electrode
NTC 10 Kohm

Output: 4/20 mA dc 300 ohm max.

Scale: 0.00/14.00 pH

Temperature Compensation: automatic 0/80 °C
error < ± 0.2 pH

Zero: adjustable ± 10 %

Sensitivity: adjustable from -5% to +15%

Input Current: < 2 pA

Input Resistance: > 10¹² ohm

Set points: dual

Relays contacts: SPST 220 Vac 5 A (resistive load)

Hysteresis: ± 0.4 %

Relay Time Delay: adjustable 0/40 s

Operating Temperature: 0/50 °C

Operating Humidity: 0/95% R.H. non-condensing

Power Supply: 110/220 V 50/60 Hz 3 VA

Terminal block: detachable

Net Weight: 265 g

Dimensions: 105 x 95 x 58 mm (6 modules)

Mounting: DIN Rail (35 x 7.5 mm Rail)

Option 091.403: 24 Vac power supply

The technical specifications could be changed without notice.

MV 3647

O.R.P. controller

- LCD Display
- Dual set points
- Set point values display
- HI/LO selectable limits
- Adjustable relay time delay
- 4/20 mA output
- DIN Rail mounting
- Detachable terminal block connectors

General informations

The O.R.P. controller incorporates a large LCD display which is easily readable even from considerable distances.

The controller will display set point values by depressing a button on the front panel next to the corresponding adjustment potentiometer.

The HI/LO function may be selected for each relay.

Dead Band relay adjustment allows relay activation to be delayed from 0/40 Seconds.

The 4/20 mA output is available for input into recorders or other devices requiring a 4/20 mA input signal.

Zero and Sensitivity (Span) calibration adjustments are located on the front panel and are easily accessible.

The controller may be powered by an external power supply 110/220 Vac.

All plastic construction provides maximum resistance to corrosion.

Detachable terminal block connectors and DIN Rail mounting provide for easy field installation.

Accessories

See Series 3000 accessories.



Specifications

Display: LCD

Input: O.R.P. electrode

Output: 4/20 mA dc 300 ohm max.

Scale: 0/1000 mV

Zero: adjustable $\pm 10\%$

Sensitivity: adjustable from -5% to $+15\%$

Input Current: $< 2\ \mu\text{A}$

Input Resistance: $> 10^{12}\ \text{ohm}$

Set points: dual

Relays contacts: SPST 220 Vac 5 A resistive

Hysteresis: $\pm 0.4\%$

Relay Time Delay: adjustable 0/40 Seconds

Operating Temperature: 0/50 °C

Operating Humidity: 0/95% R.H. non-condensing

Power Supply: 110/220 V 50/60 Hz 3 VA

Terminal block: detachable

Net Weight: 265 g

Dimensions: 105 x 95 x 58 mm (6 modules)

Mounting: DIN Rail (35 x 7.5 mm Rail)

Option 091.403: 24 Vac Power supply

The technical specifications could be changed without notice.

SENSORES DE pH Y O.R.P.

Transmisores

DPF
sensors

3630 Models

Two-wire transmitters

PH 3630

pH Transmitter

MV 3630

O.R.P. Transmitter

- Two wire 4/20 mA operation
- Isolated current loop output
- LCD display
- Automatic or Manual Temperature Compensation (pH)
- Temperature display (pH)
- 10/30 Vdc power supply
- Direct connection to PC's
- Din Rail mounting
- Detachable terminal block connectors

General informations

pH and O.R.P. transmitters incorporate a large LCD display which is easily readable even from considerable distances.

Transmitters are powered by an external power supply from 10 to 30 Vdc. The same two wires which provide power to the transmitter also carry the 4/20 mA output pH signal.

Zero and Sensitivity (span) calibration adjustments are located on the front panel and are easily accessible.

The 4/20 mA output is isolated for input into recorders or other devices requiring a 4/20 mA signal.

The input/output isolation also allows input into PLC, DCS or Personal Computers accepting 4/20 mA signals.

A common power supply may be used to power other transmitters without interference from other measurement devices or sensors.

All plastic construction provides maximum resistance to corrosion. Detachable terminal block connectors and Din Rail mounting provide for easy field installation.

The PH 3630 transmitter will display temperature values of manual or automatic temperature compensation devices. Automatic Temperature Compensation is achieved with use of a 100 ohm platinum RTD.



Specifications

Display: LCD

Inputs pH 3630: pH electrode Pt100 3 wire

Input MV 3630: O.R.P. electrode

Output: 4/20 mA dc isolated

Scales PH 3630: 0/14.00 pH -10.0/120.0 °C

Scale MV 3630: 0/1000 mV

Temperature Compensation: manual or automatic (PH 3630 only)

Zero: adjustable $\pm 15\%$

Sensitivity: adjustable from 86% to 112%

Input Current: $< 2 \mu\text{A}$

Input Resistance: $> 10^2 \text{ ohm}$

Operating Temperature: 0/50 °C

Operating Humidity: 0/95% R.H. non-condensing

Power supply: 10/30 Vdc

Isolation: 500 V input to output

Terminal block: detachable

Net Weight: 200 g

Dimensions: 105 x 95 x 58 mm (6 modules)

Mounting: DIN Rail (35 x 7.5 mm Rail)

The technical specifications could be changed without notice.

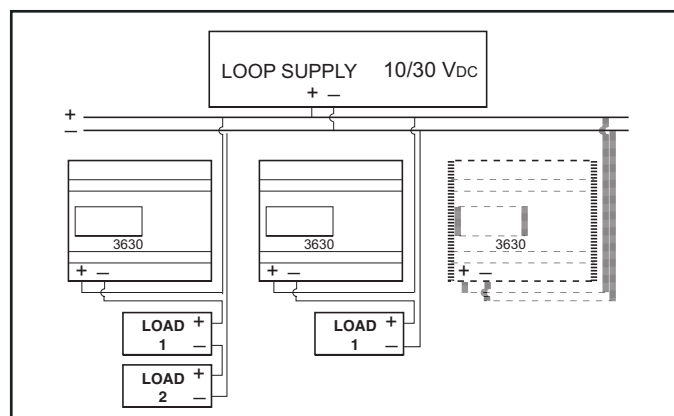
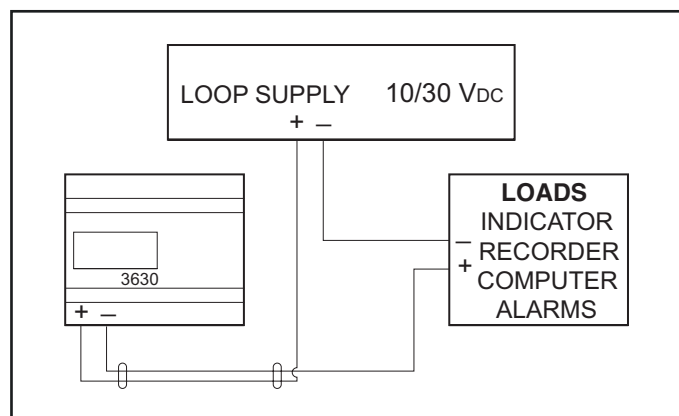

SENSORES DE pH Y O.R.P. Transmisores Portátiles

DPF
sensors

MICROTRANSMITTERS for industrial probes

- Suitable for 7685 Series and 565 Series
- IP 65 water-tight protection
- Water-tight output connector
- For immersion and in-line probes
- Easy installation and maintenance

080102.1 pH and O.R.P. microtransmitter

New



The microtransmitter is a differential preamplifier enclosed in a water-tight housing and makes the characteristics of the measuring electrodes signal compatible to those of a normal connection cable.

With this technically advanced solution it is possible to make connections at considerably long distances between the measuring probe and the control panel without the use of a shielded cable maintaining a high signal response speed and the complete absence of interferences, therefore greater precision.

The connection between the microtransmitter and the panel regulator is made using a 4-pin waterproof connector type SZ 9490 and a normal 4-wire cable.

The accessory type SZ 9491 consisting of SZ 9490 + 10 m marked cable is available.

The microtransmitter is protected against eventual connection inversions. It is mounted in the usual way on ST type probes.

For unfixed mounting, the SZ 911 accessory must be used.
Recommended cable: 4 x 0.5 mm or 4 x 0.75 mm non shielded.

Accessories

- SZ 9490 IP 67 connector for cable
- SZ 9491 10 mt cable and SZ 9490 connector
- SZ 911 Stopper

PH 125.2 pH - ORP - °C meter



- High accuracy and reliability
- LCD display
- Temperature visualization
- Automatic or manual Temperature compensation
- Corrosion resistant

This instrument is designed for field applications in waste water, swimming pools, chemical, electroplating and food industries. By pressing any key the instrument will switch on or will extend the operation for about 5 minutes.

The temperature compensation on the pH readout is automatic or manual. The zero and sensitivity adjustment allows a very accurate calibration of the meter.

The plastic case with the polycarbonate membrane provide a corrosion resistance in field applications.

Accessories and sensors

to be ordered separately

BC 921: carrying case

SZ 959: buffer solutions 4/7/9 pH 50 cc.

SZ 142 - SZ 161 - SZ 1031: suggested pH electrodes

SZ 251: suggested ORP electrode

SP 51501 - SP 51511: suggested temperature sensors

Specifications

Display: LCD 3 1/2 digit

Scales: 0/14.00 pH ±1000 mV -20.0/+120.0 °C

Zero: ± 15 %

Sensitivity: ± 20 % (pH only)

Input: from pH/ORP electrodes, BNC connectors
from Pt1000, jack connector

Power: 9 V battery

Battery life: 100 hours operation

Dimensions: 92 x 155 x 33 mm

Weight: 300 g

SENSORES DE pH

TABLA DE SELECCIÓN



MODELO	MEMBRANA CUERPO	R. MΩ a 25 °C	RANGO en pH	RANGO TEMP.	DIMENSIONES L X Ø en mm.	REFERENCIA	APLICACION	USO	CONTROLADORES INDICADORES
SZ 142	GX2 Epoxy	50	0...13	0...60	110 X 12 1,5 m conector	Ag/AgCl	Agua limpia, piscinas	Equipos portátiles	PH 125.2 PORTATIL
SZ 145	GX2 Epoxy	50	0...13	0...60	110 X 12 9 m cable	Ag/AgCl	Agua limpia, Industrial	En línea, < 7 bar	PH 65.2 / PH3647 / PH3630
SZ 1021	GX2 Epoxy	50	0...13	0...60	110 X 12 1 m cable	Ag/AgCl	Agua limpia, piscinas	Equipos portátiles	PH125.2 PORTATIL
SZ 1025	GX2 Epoxy	50	0...13	0...60	110 X 12 9 m cable	Ag/AgCl	Agua limpia, Industrial	En línea, < 7 bar	PH565.2 / PH3647 / PH3630
SZ 151	GX2 Epoxy	100	0...13	-5...130	110 X 12 1,5 m conector	Ag/AgCl Y KN03	Líquidos muy contaminados	Alta temperatura	TODOS + TRANSMISORES
SZ 160	GX2 Cristal	50	0...13	0...100	110 X 12 Conector SZ	Ag/AgCl	Líquidos contaminados	Equipos portátiles	PH 125.2 PORTATIL
SZ 161	GX2 Cristal	50	0...13	0...100	110 X 12 1,5 m conector	Ag/AgCl	Líquidos contaminados	Equipos portátiles	PH 125.2 PORTATIL
SZ 165	GX2 Cristal	50	0...13	0...100	110 X 12 9 m cable	Ag/AgCl	Propósito general	Estándar uso industrial	TODOS + TRANSMISORES
SZ 171	GX2 Cristal	50	0...13	0...100	110 X 12 1,5 m conector	Ag/AgCl Y KN03	Líquidos contaminados	Equipos portátiles	PH 125.2 PORTATIL
SZ 173	GX2 Cristal	50	0...13	0...100	110 X 12 9 m cable	Ag/AgCl Y KN03	Líquidos contaminados	Estándar uso industrial	TODOS + TRANSMISORES
SZ 191	GX2 Cristal	100	0...13	5...130	110 X 12 1,5 m conector	Ag/AgCl Y KN03	Alta temperatura	O.E.M.	TODOS + TRANSMISORES
SZ 195.1	GX3 dome Cristal	200	0...14	-5...130	110 X 12 9 m cable	Ag/AgCl Y KN03	Líquidos contaminados	Alta temperatura	TODOS + TRANSMISORES
SZ 1031	GX2 Cristal	50	0...13	0...80	110 X 12 1,5 m conector	Ag/AgCl	Líquidos muy contaminados	Electrodo rellenable	PH 125.2 PORTATIL
SZ 1075	Antimonio Cristal	--	2...11	-5...100	110 X 12 9 m cable	Ag/AgCl	Líquidos ácidos con HF	Industrial	PH7685 / PH7685.010
SZ 1093	GX2 Epoxy	50	0...13	0...80	80 X 12 3 m conector	Ag/AgCl	Invernaderos Agricultura	Hidropónico	TODOS + TRANSMISORES
SZ 1131	GX1 Epoxy	300	0...12	-5...100	110 x 9,5 1 m conector	Ag/AgCl	Invernaderos Agricultura	Para pinchar	TODOS + TRANSMISORES
SZ 1140	GX2 PVDF	50	0...12	0...100	140 X ¾" NPT 8 m conector	Ag/AgCl Y KN03	Líquidos contaminados	AUTOLIMPIABLE Uso industrial	TODOS + TRANSMISORES
SZ 1150	GX2 PVDF	50	0...12+ Pt100	0...100	140 X ¾" NPT 8 m conector	Ag/AgCl Y KN03	Líquidos contaminados	AUTOLIMPIABLE Uso industrial	TODOS + TRANSMISORES
TS 284	GX2	50	0...14	0...100	370 X 38	Ag/AgCl	Sumergible	Pozos, rios	4...20 mA